

Callout	Component Name
Preliminary Procedure Remove the front wheelhouse liner. Refer to Front Wheelhouse Front Liner Replacement (Traverse) or Front Wheelhouse Front Liner Replacement (Outlook).	
1	Front Bumper Fascia Brace Bolt Caution: Refer to Fastener Caution. Tighten 25 N·m (18 lb ft).
2	Front Bumper Fascia Brace Nut Tighten 9 N·m (80 lb in).
3	Fender Bumper Fascia Brace

Front Bumper Fascia Upper Support Replacement (Enclave)

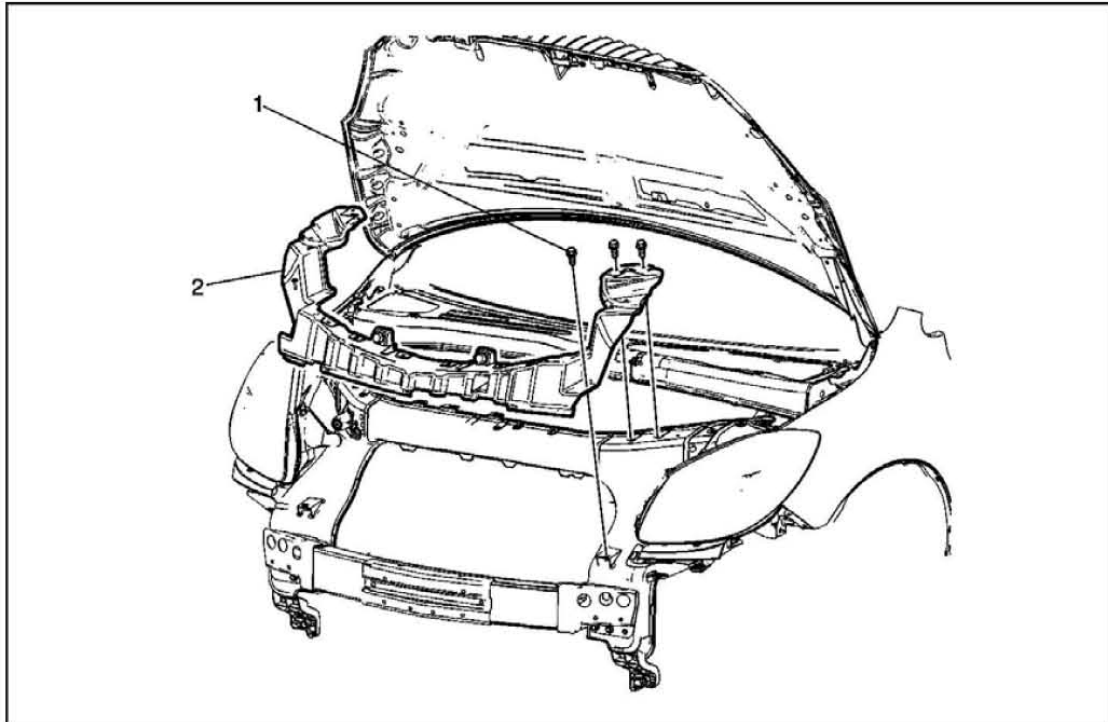

Callout	Component Name
Preliminary Procedures	
1. Remove the front bumper fascia. Refer to Front Bumper Fascia Replacement (Acadia) or Front Bumper Fascia Replacement (Enclave) or Front Bumper Fascia Replacement (OUTLOOK) or Front Bumper Fascia Replacement (Traverse) . 2. Remove the hood primary and secondary latch. Refer to Hood Primary and Secondary Latch Replacement. 3. Remove the radiator upper support mounting bolts and position rearward.	
1	Front Bumper Fascia Support Bolt (Qty: 6) Caution: Refer to Fastener Caution . Tighten 10 N·m (89 lb in)
2	Front Bumper Fascia Support

Front Bumper Fascia Upper Support Replacement (Outlook, Acadia)

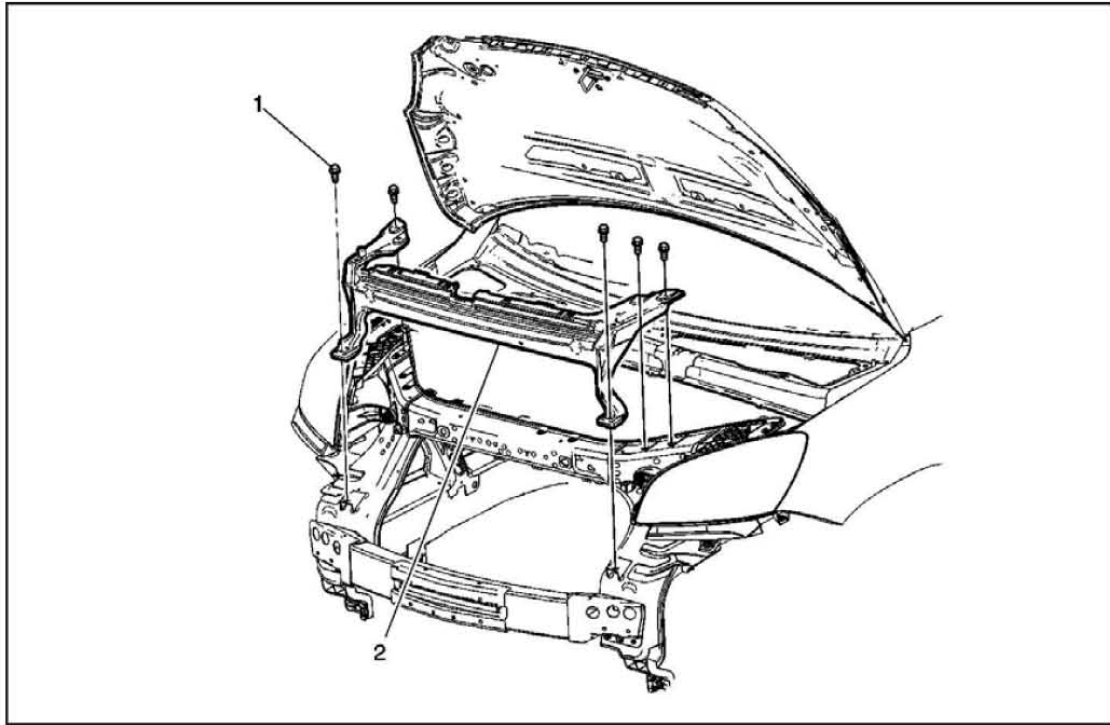

Callout	Component Name
Preliminary Procedures 1. Remove the front bumper fascia. Refer to Front Bumper Fascia Replacement (Acadia) or Front Bumper Fascia Replacement (Enclave) or Front Bumper Fascia Replacement (OUTLOOK) or Front Bumper Fascia Replacement (Traverse). 2. Remove the hood latch support. Refer to Hood Latch Support Replacement. 3. Remove the radiator upper support mounting bolts and position rearward.	
1	Front Bumper Fascia Support Bolt (Qty: 6) Caution: Refer to Fastener Caution Tighten 10 N·m (89 lb in)
2	Front Bumper Fascia Support

Front Air Deflector Replacement (Acadia)

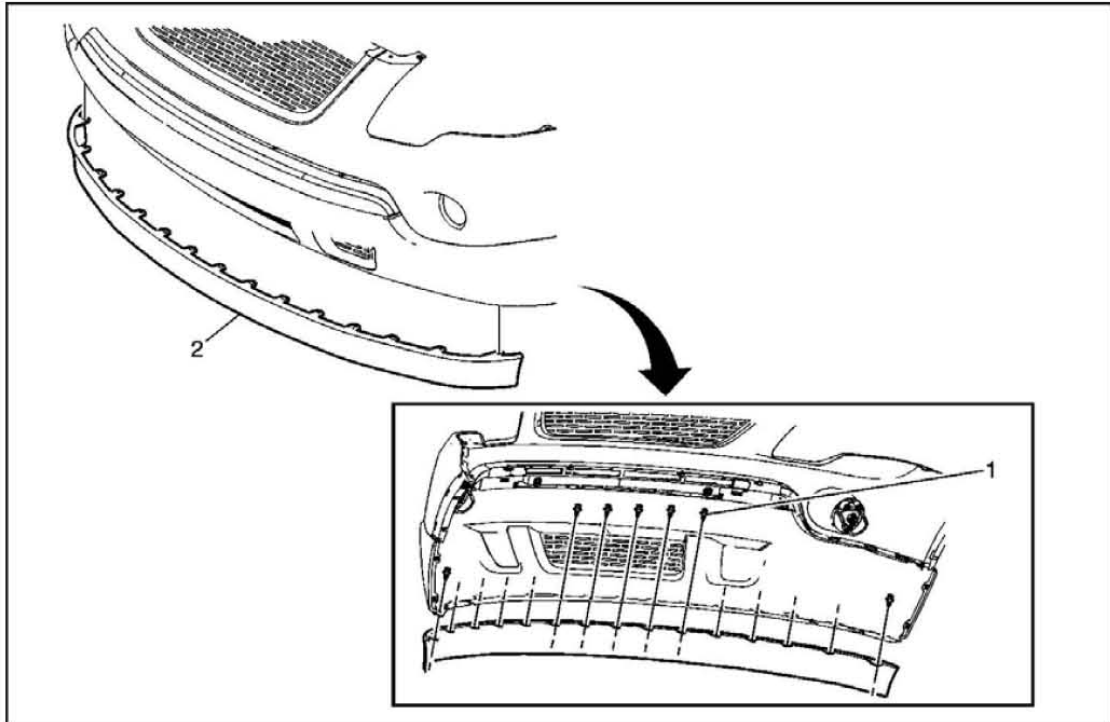

Callout	Component Name
Preliminary Procedure	
Remove the front bumper fascia bracket. Refer to Front Bumper Fascia Bracket Replacement (Acadia) or Front Bumper Fascia Bracket Replacement (Outlook).	
1	Front Bumper Air Deflector Plastic Retainers (Qty: 15)
2	Front Bumper Fascia Extension

Front Air Deflector Replacement (Traverse)

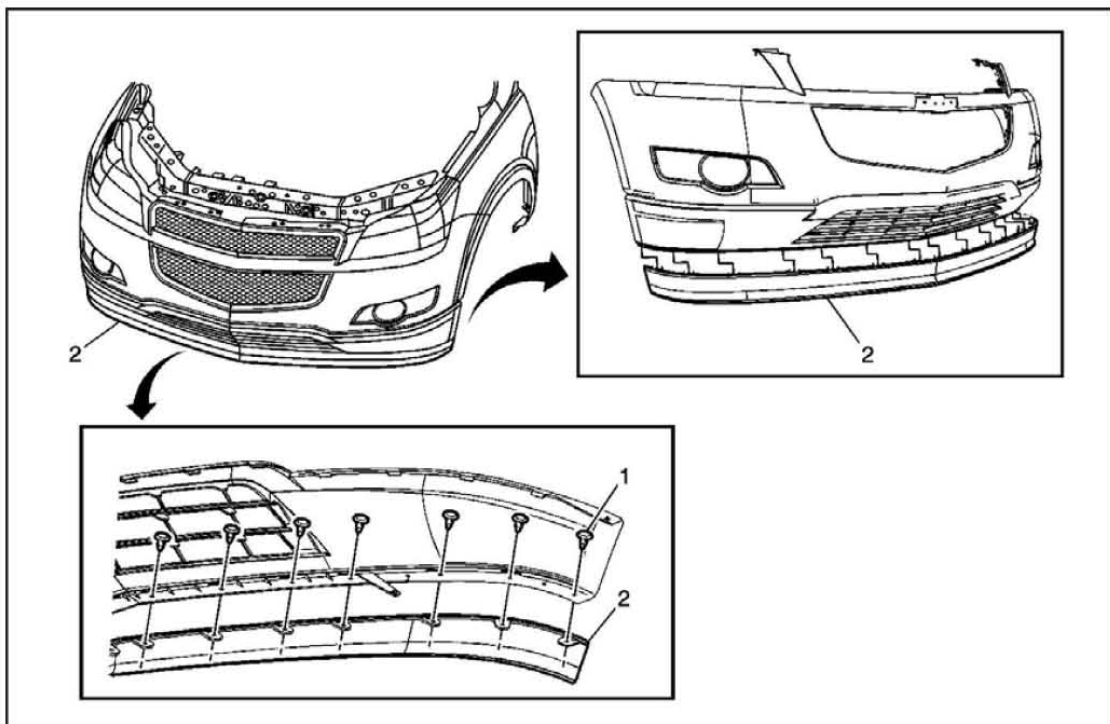

Callout	Component Name
Preliminary Procedure Remove the front wheelhouse front liner. Refer to Front Wheelhouse Front Liner Replacement (Traverse) or Front Wheelhouse Front Liner Replacement (Outlook).	
1	Front Bumper Air Deflector Plastic Retainer (Qty: 14)
2	Front Bumper Air Deflector Procedure Remove the deflector pulling forward to release the retainer tabs.

Front Air Deflector Replacement (Enclave)

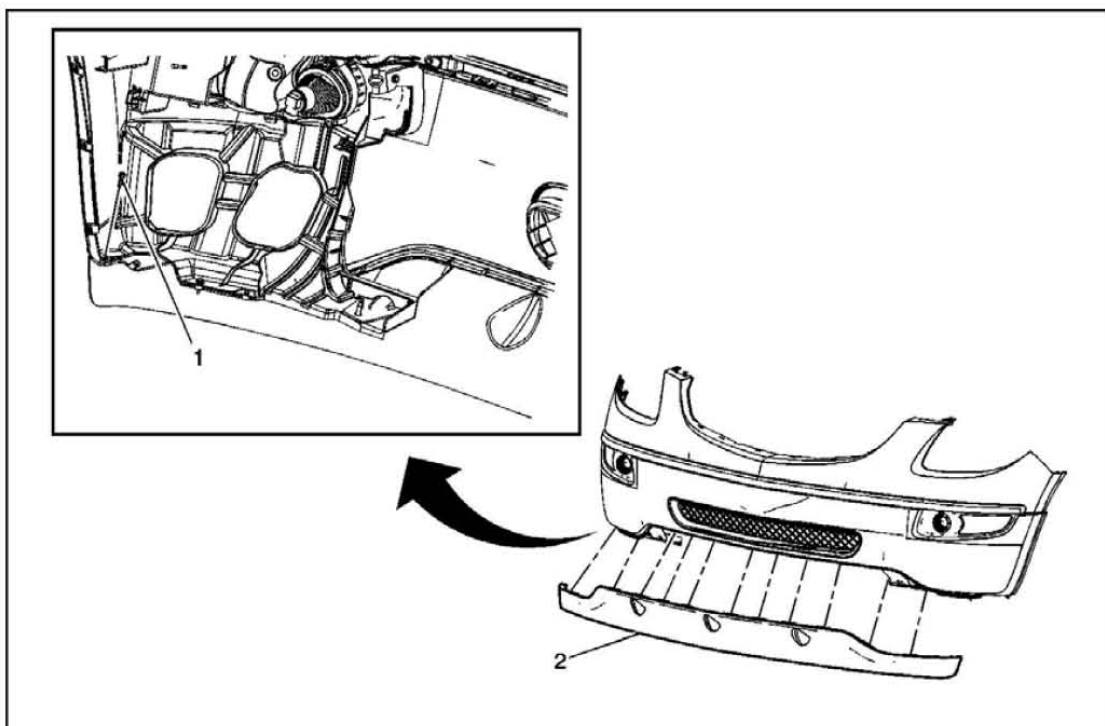

Callout	Component Name
Preliminary Procedures 1. Remove the Parking and Front Fog Lamp Bracket. Refer to Parking and Front Fog Lamp Bracket Replacement (Enclave). 2. Raise and support the vehicle. Refer to Lifting and Jacking the Vehicle.	
1	Front Bumper Air Deflector Bolts (Qty: 2) Caution: Refer to Fastener Caution. Tighten 2 mm N·m (0.79 lb in)
2	Front Bumper Fascia Air Deflector

Rear Bumper Fascia Replacement

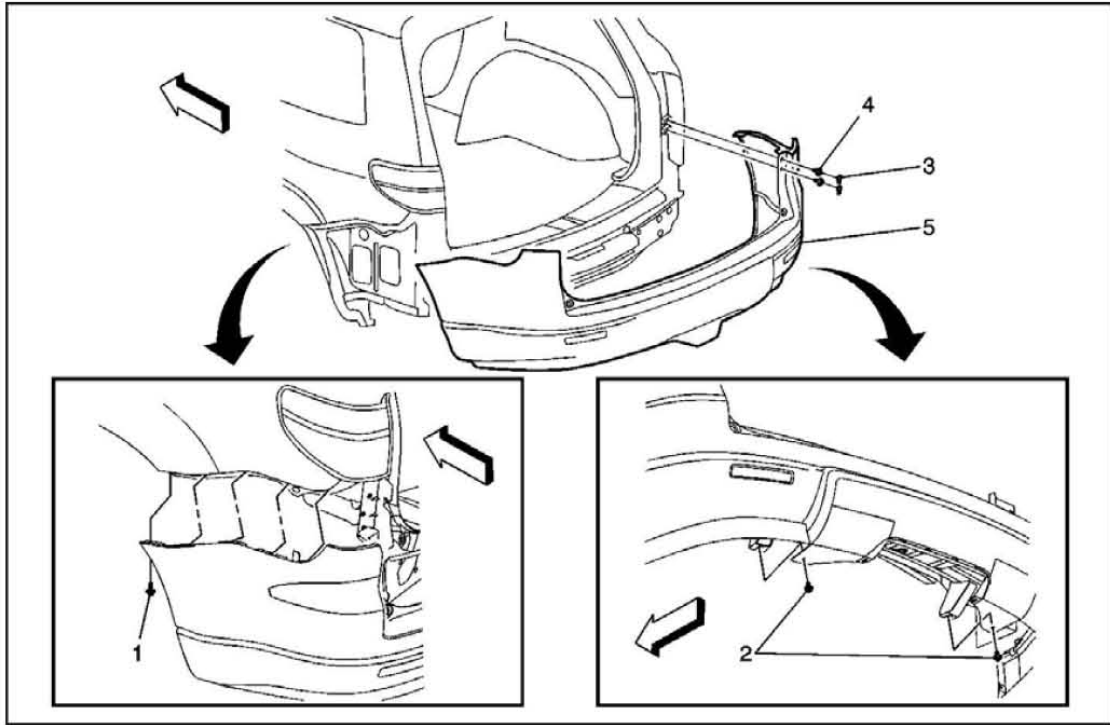

Callout	Component Name
Preliminary Procedure	
Remove the right and left rear wheelhouse. Refer to Rear Wheelhouse Panel Liner Replacement.	
1	Rear Fascia Bolt (Qty: 2)
2	Rear Fascia Retainers (Qty: 2)
3	Rear Fascia Bolt Cover (Qty: 24)
4	Rear Bumper Fascia Screw (Qty: 8) Caution: Refer to Fastener Caution. Tighten 2 N·m (18 lb in)
5	Rear Fascia Procedure <ul style="list-style-type: none"> • Disconnect the electrical connectors/harnesses as needed. • Transfer any parts as needed.

Rear Bumper Upper Fascia Replacement

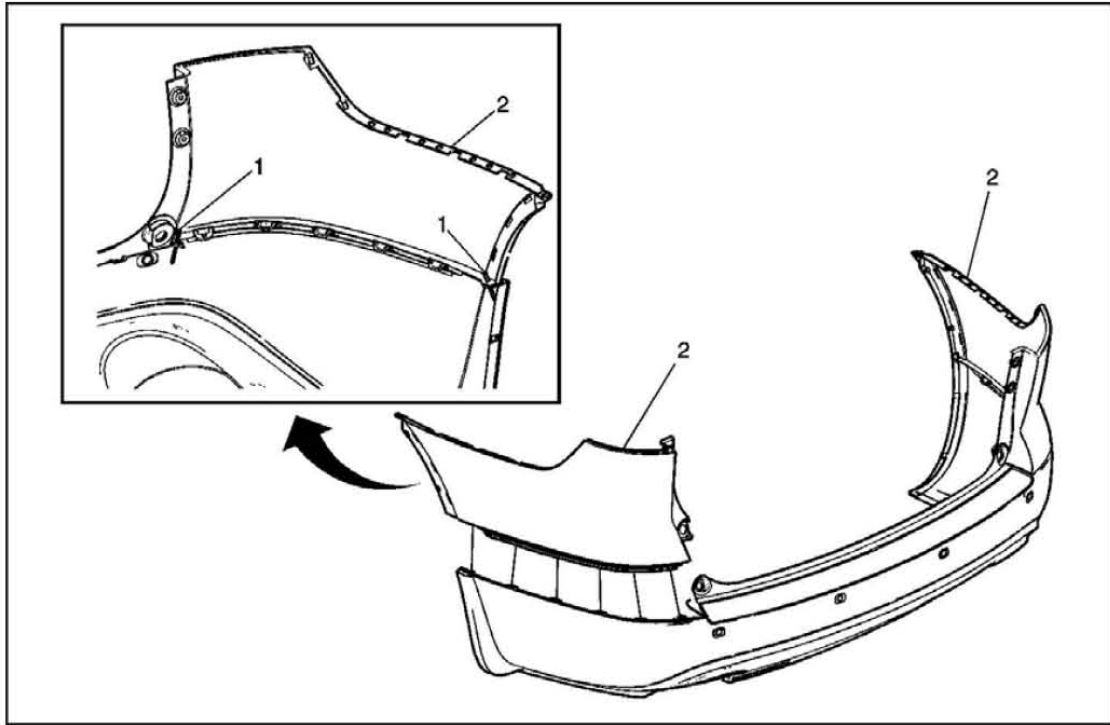

Callout	Component Name
Preliminary Procedure Remove the bumper fascia. Refer to Rear Bumper Fascia Replacement.	
1	Rear Bumper Upper Fascia Rivet (Qty: 2) Warning: SIO-ID = 2053405 LMD = 25-jan-2008 Approved safety glasses and gloves should be worn when performing this procedure to reduce the chance of personal injury. Procedure Drill out the rivets before removing the upper fascia.
2	Rear Bumper Upper Fascia Tip: Use a flat-bladed tool to release the tabs.

Rear Bumper Fascia Support Replacement

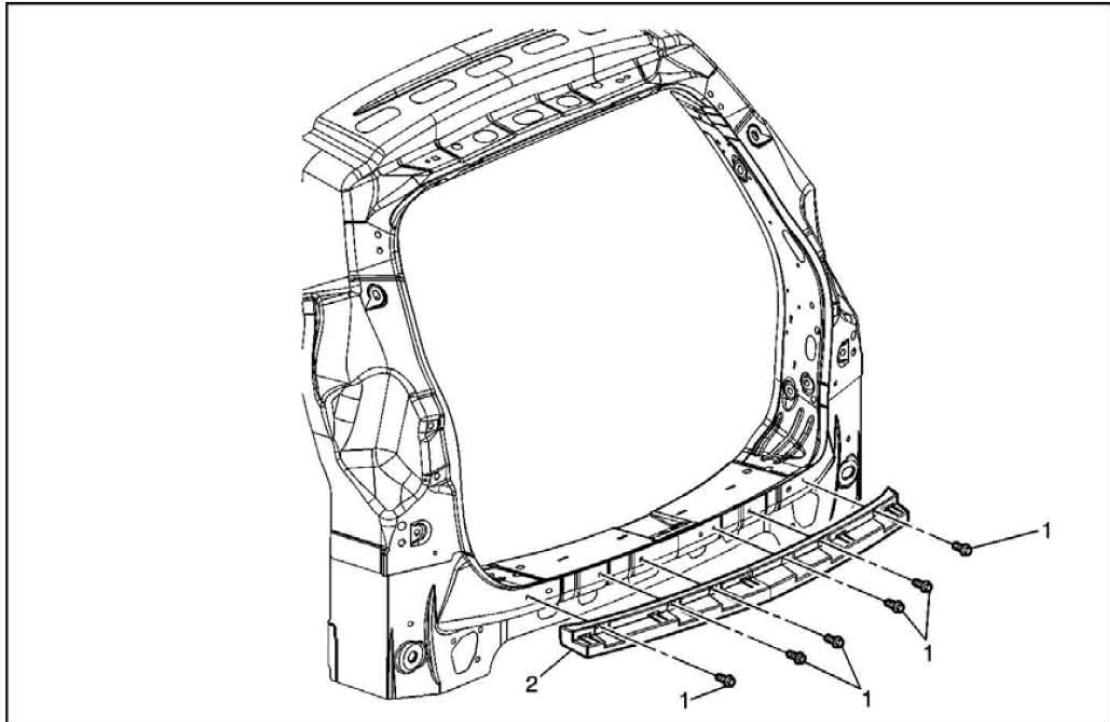

Callout	Component Name
Preliminary Procedure Remove the rear bumper fascia. Refer to Rear Bumper Fascia Replacement.	
1	Rear Bumper Fascia Support Bolt (Qty: 6) Caution: Refer to Fastener Caution. Tighten 5 N·m (44 lb in)
2	Rear Bumper Fascia Support

Rear Bumper Fascia Reinforcement Replacement

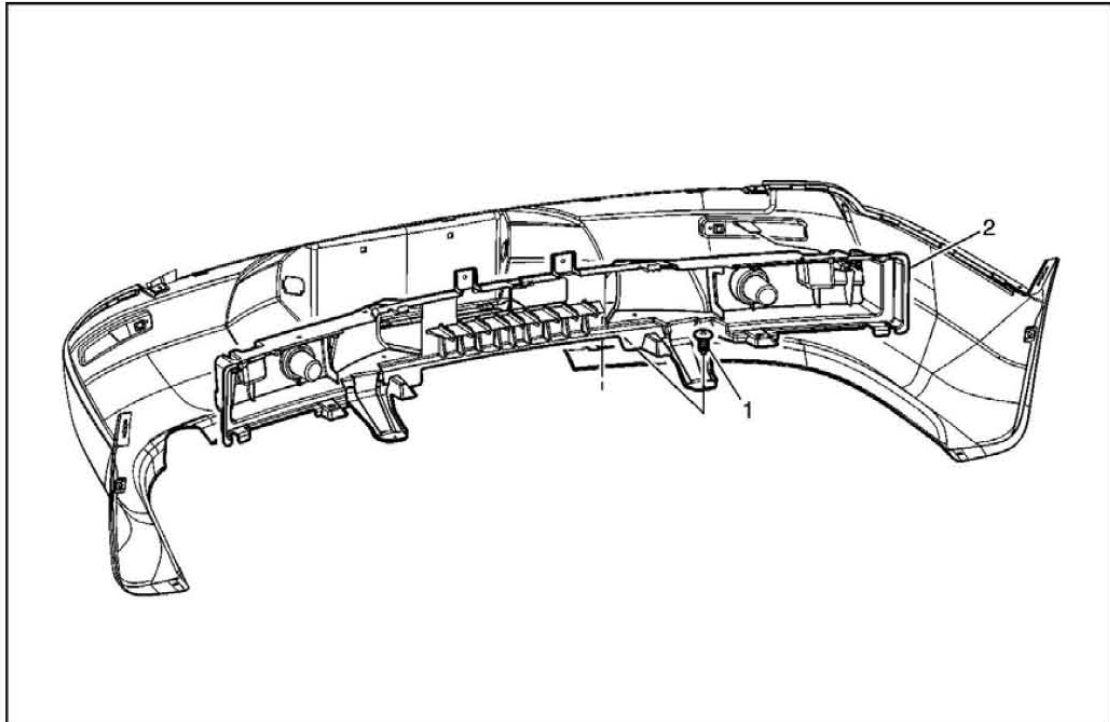

Callout	Component Name
Preliminary Procedure	
Remove the rear bumper fascia. Refer to Rear Bumper Fascia Replacement.	
1	Rear Bumper Fascia Reinforcement Retainer (Qty: 2)
2	Rear Bumper Fascia Reinforcement

Rear Bumper Impact Bar Replacement

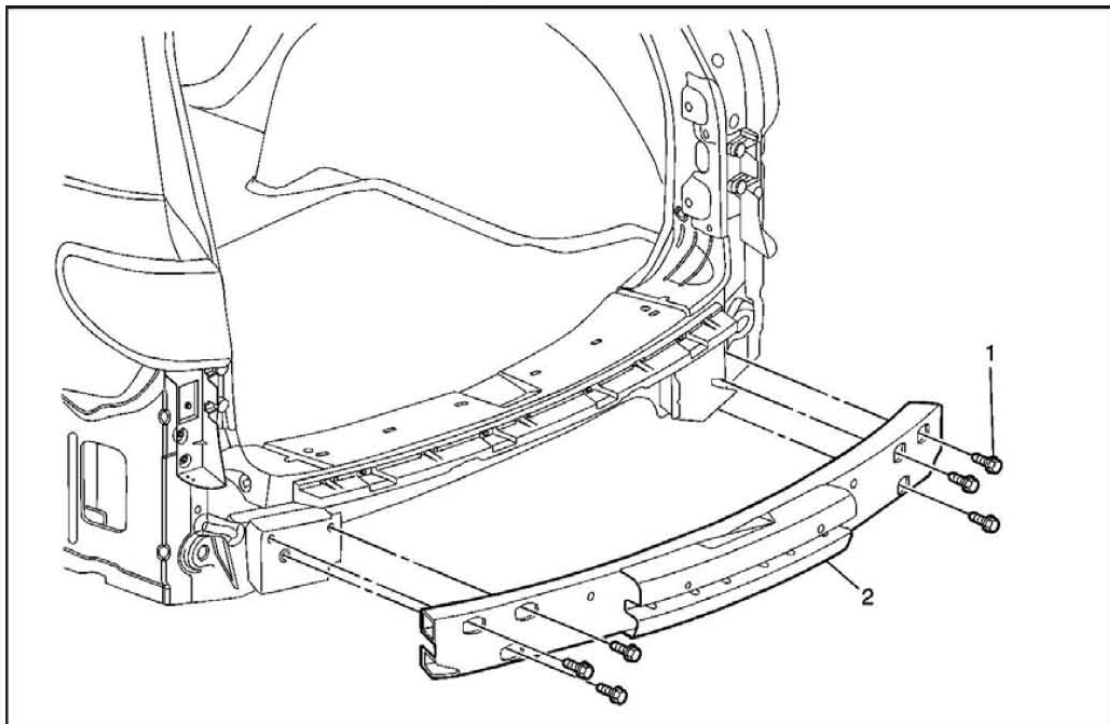

Callout	Component Name
Preliminary Procedure Remove the bumper fascia. Refer to Rear Bumper Fascia Replacement.	
1	Rear Bumper Impact Bar Bracket Bolt (Qty: 6) Caution: Refer to Fastener Caution. Tighten 30 N·m (22 lb ft)
2	Rear Bumper Impact Bar Procedure 1. Unclip the electrical harness from the impact bar. 2. Transfer the necessary components.

Rear Bumper Step Pad Replacement

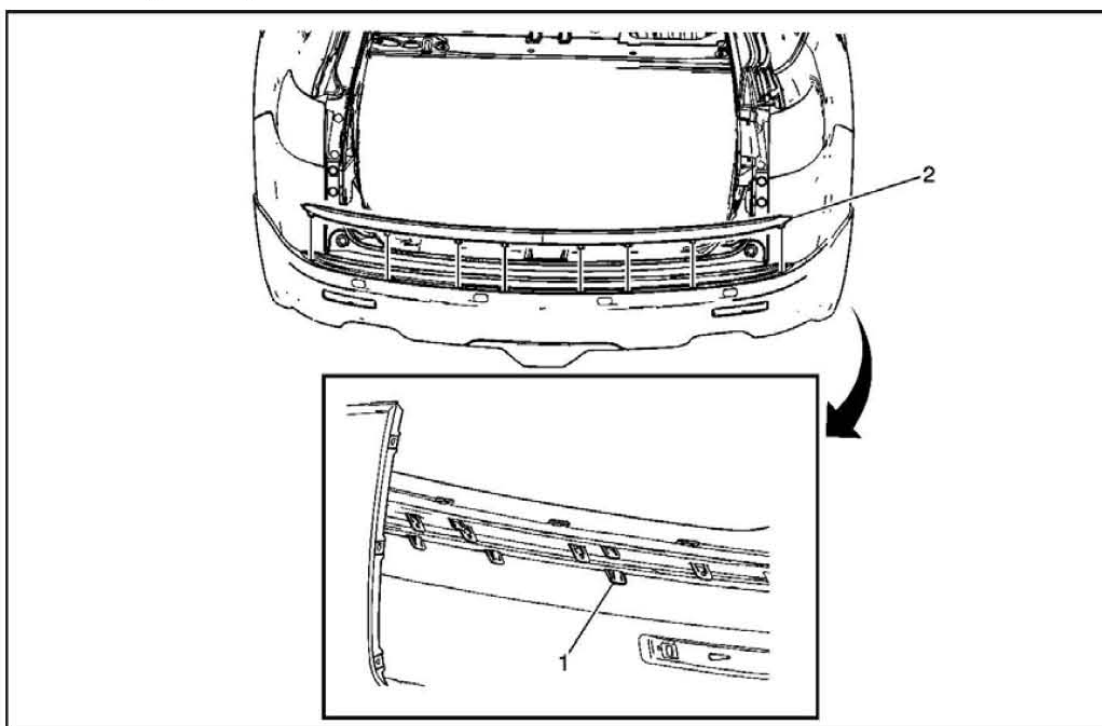

Callout	Component Name
Preliminary Procedure Remove the rear bumper fascia. Refer to Rear Bumper Fascia Replacement.	
1	Rear Fascia Step Pad Procedure Reach under the backside of the rear fascia and squeeze the pad clips to release the step pad from the fascia assembly.
2	Rear Bumper Step

Rear Bumper Fascia Reflector Replacement (Acadia and OUTLOOK)

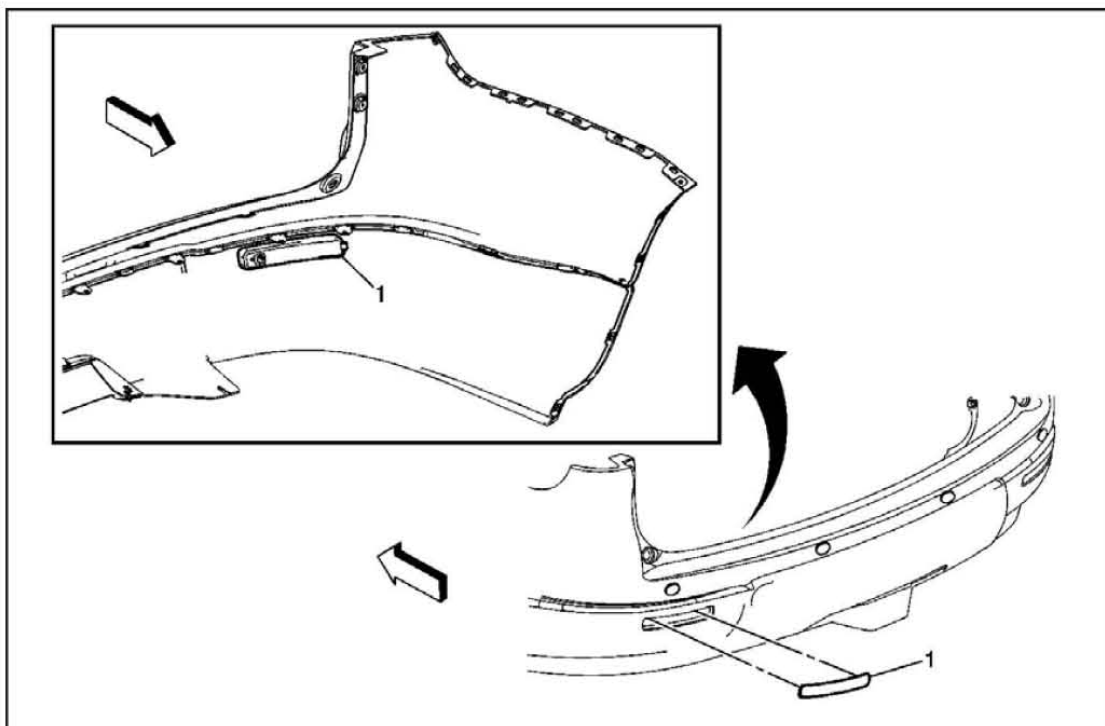

Callout	Component Name
Preliminary Procedure Remove the rear bumper fascia reinforcement. Refer to Rear Bumper Fascia Reinforcement Replacement	
1	Rear Bumper Fascia Reflector Tip: Push forward on the tab in order to remove the reflector from the fascia.

Rear Bumper Fascia Reflector Replacement (Enclave and Traverse)

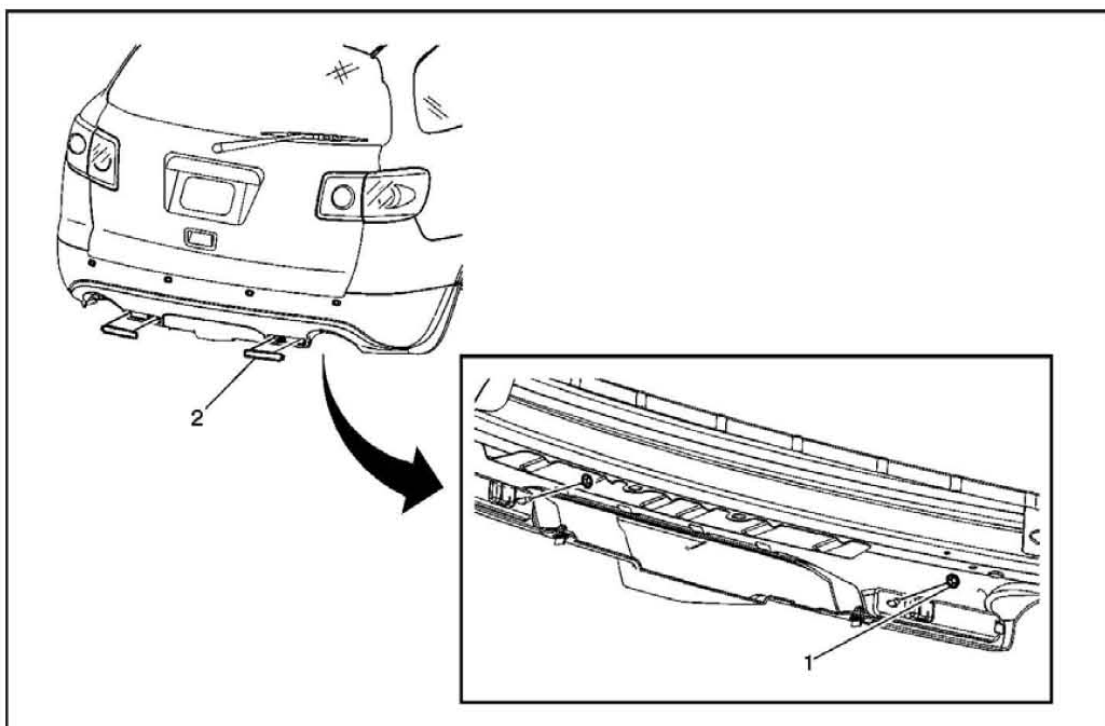

Callout	Component Name
Preliminary Procedure	
Raise and support the vehicle with suitable safety stands. Refer to Lifting and Jacking the Vehicle	
1	Rear Bumper Fascia Reflector Bolts (Qty: 2) Caution: Refer to Fastener Caution. Tighten 9 N·m (80 lb in)
2	Rear Bumper Fascia Reflector

Rear Bumper Fascia Insert Replacement

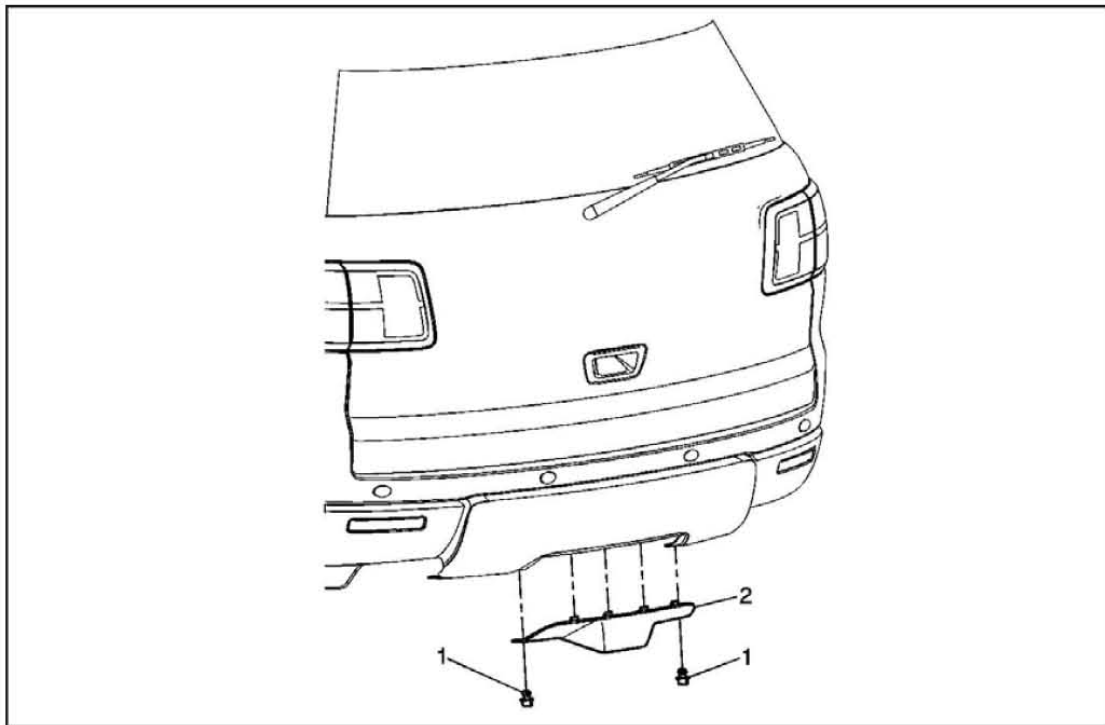

Callout	Component Name
1	Rear Fascia Bumper Insert Replacement Plastic Retainer (Qty: 2) Tip: Turn the retainers to remove.
2	Rear Fascia Bumper Insert