

B1364 B1370 SEAT BELT PRETENSIONER

DTC DESCRIPTION

The Seat Belt Pretensioner consists of the SRSCM and two Seat Belt Pretensioners (BPT). The SRSCM sets above DTC(s) if it detects short to ground on the BPT circuit.

DTC	FAULT DESCRIPTION
B1364	SEAT BELT PRETENSIONER [FRONT-DRIVER] CIRCUIT SHORT TO BATTERY
B1370	SEAT BELT PRETENSIONER [FRONT-PASSENGER] CIRCUIT SHORT TO BATTERY

DTC DETECTING CONDITION

DTC	Condition	Probable cause
B1364 B1370	<ul style="list-style-type: none"> • Short to ground between BPT and SRSCM • Seat Belt Pretensioner (BPT) Malfunction • SRSCM Malfunction 	<ul style="list-style-type: none"> • Short to battery line circuit on wiring harness • Seat Belt Pretensioner (BPT) squib • SRSCM

SCHEMATIC DIAGRAM

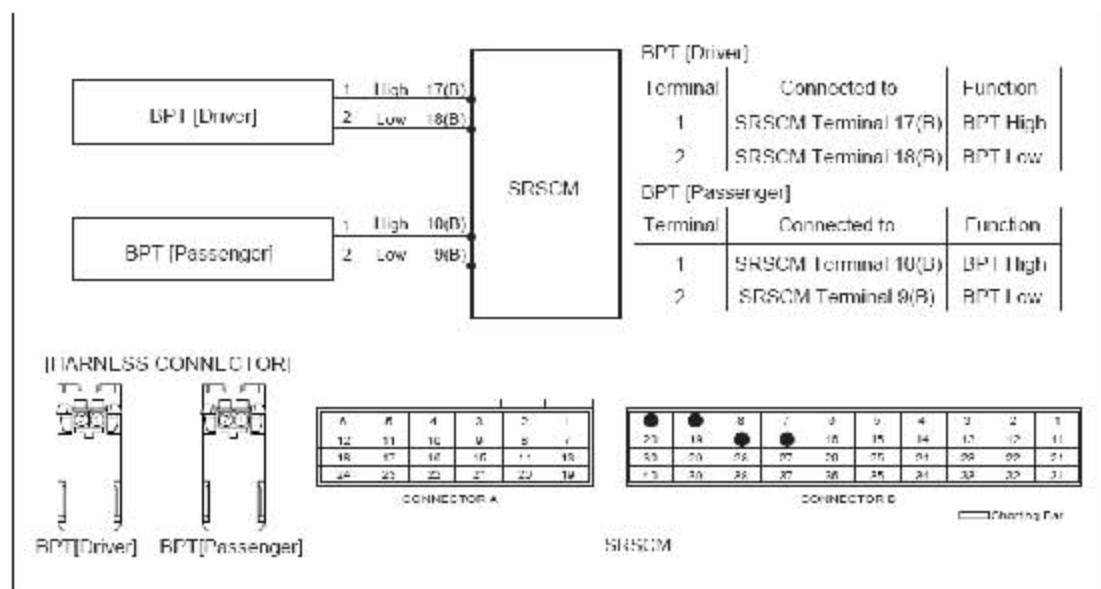

TERMINAL & CONNECTOR INSPECTION

Refer to the DESCRIPTION in this TROUBLESHOOTING section.

INSPECTION PROCEDURE

1). PREPARATION.

Refer to the DESCRIPTION in this TROUBLESHOOTING section.

2). CHECK SHORT TO BATTERY LINE

A) Connect the battery negative cable to the battery.

B) Turn the ignition switch to ON.

C) Measure voltage between the terminal 1 of BPT harness connector and chassis ground.

Specification (voltage) : 0 V

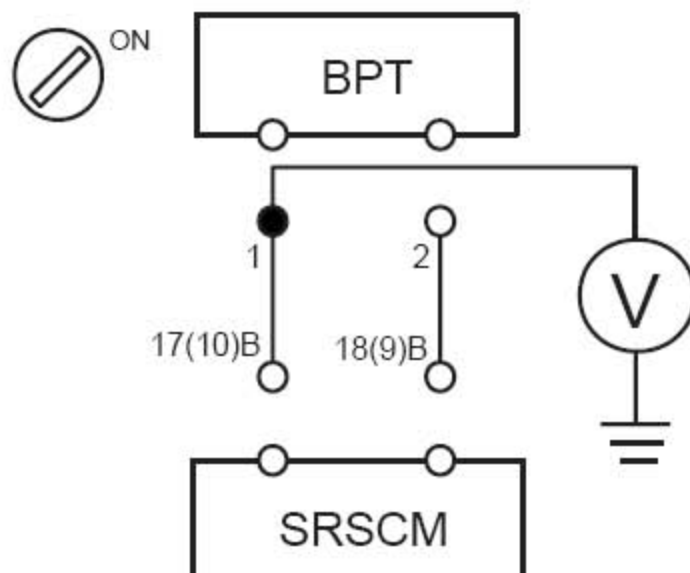

D) Is the measured voltage within specification?

YES

▶ Check the BPT Module.

NO

▶ Repair the short to battery line circuit on wiring harness between the BPT and the SRSCM.

3). CHECK THE BPT MODULE

A) Replace the Belt Pretensioner (BPT) with a new one.

Refer to "Belt Pretensioner (BPT)" section in this SERVICE MANUAL.

B) Install the DAB module and connect the DAB connector.

C) Connect the connectors of the PAB, SAB, CAB, BPT, FIS and SIS.

- D) Connect the SRSCM connector.
- E) Connect the battery negative cable to the battery.
- F) Connect a Hi-Scan(Pro) to the data link connector.
- G) Turn the ignition switch to ON and check the vehicle again.
 - Does Hi-Scan (Pro) indicate any DTC related to Belt Pretensioner (BPT)?

YES

- ▶ Go to next step..

NO

- ▶ Replace BPT module.

5). CLEAR THE DTC AND CHECK THE VEHICLE AGAIN

Refer to the DESCRIPTION in this TROUBLESHOOTING section.