

B1381 、 B1385 SIDE AIRBAG CIRCUIT

DTC DESCRIPTION

The Side Airbag circuit consists of the SRSCM and two Side Airbags (SAB).
The SRSCM sets above DTC(s) if it detects short to ground on the SAB circuit.

DTC	FAULT DESCRIPTION
B1381	SIDE AIRBAG [FRONT-DRIVER] CIRCUIT SHORT TO BATTERY
B1385	SIDE AIRBAG [FRONT-PASSENGER] CIRCUIT SHORT TO BATTERY

DTC DETECTING CONDITION

DTC	Condition	Probable cause
B1381 B1385	<ul style="list-style-type: none"> • Short to ground between SAB and SRSCM • Side Airbag (SAB) Malfunction • SRSCM Malfunction 	<ul style="list-style-type: none"> • Short to ground circuit on wiring harness • Side Airbag (SAB) squib • SRSCM

SCHEMATIC DIAGRAM

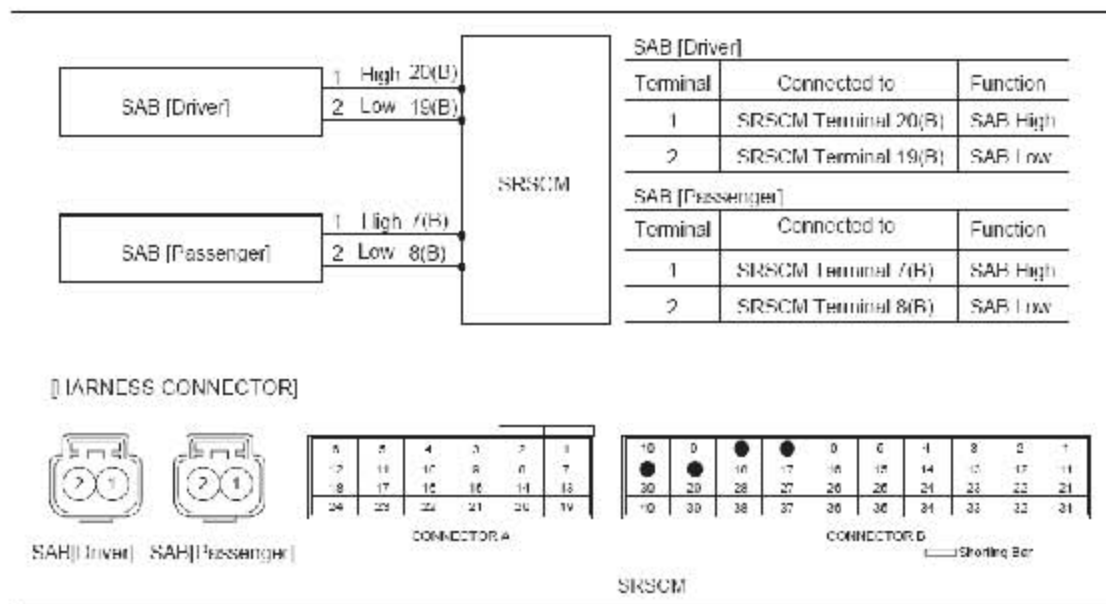

TERMINAL & CONNECTOR INSPECTION

Refer to the DESCRIPTION in this TROUBLESHOOTING section.

INSPECTION PROCEDURE

1). PREPARATION.

Refer to the DESCRIPTION in this TROUBLESHOOTING section.

2). CHECK SHORT TO BATTERY LINE

A) Connect the battery negative cable to the battery.

B) Turn the ignition switch to ON.

C) Measure voltage between the terminal 1 of SAB harness connector and chassis ground.

Specification (voltage) : Approximately 0 V

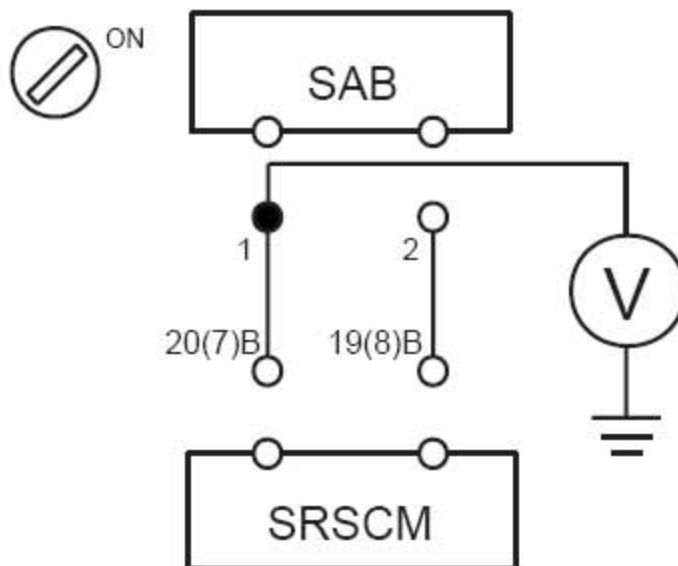

D) Is the measured voltage within specification?

YES

▶ Check the SAB Module.

NO

▶ Repair or replace the wiring harness between the SAB and the SRSCM.

3). CHECK THE SAB MODULE

A) Replace the Belt Pretensioner (BPT) with a new one.

Refer to "Belt Pretensioner (BPT)" section in this SERVICE MANUAL.

B) Install the DAB module and connect the DAB connector.

C) Connect the connectors of the PAB, SAB, CAB, BPT, FIS and SIS.

D) Connect the SRSCM connector.

- E) Connect the battery negative cable to the battery.
- F) Connect a Hi-Scan(Pro) to the data link connector.
- G) Turn the ignition switch to ON and check the vehicle again.
 - Does Hi-Scan (Pro) indicate any DTC related to Belt Pretensioner (BPT)?

YES

- ▶ Go to next step.

NO

- ▶ Replace SAB module.

4). CLEAR THE DTC AND CHECK THE VEHICLE AGAIN

Refer to the DESCRIPTION in this TROUBLESHOOTING section.