

Linear Valve Learn Value Initialization

Launch Software TOYOTA Engineer
Li Yongshuai

The function is available in the working supporting menu of ABS of X431 TOYOTA program. The non-CANBUS systems must be used TOYOTA-16 connector or CAN BUS II connector.

The main procedures are introduced as below:



图1



图2

Now I introduce the operation and components relating to it. While Driver is doing brake operation, pedal journey sensor detects the brake intention of driver, which the sensor transfer to ECU. ECU collects the signals from rpm sensor, steering angle sensor, etc, work out the brake power of every wheel according to the driving status, and send command to pressure storage can of executor to execute the brake of every wheel. Fig. 3 shows that how brake control ECU follows the brake intention.

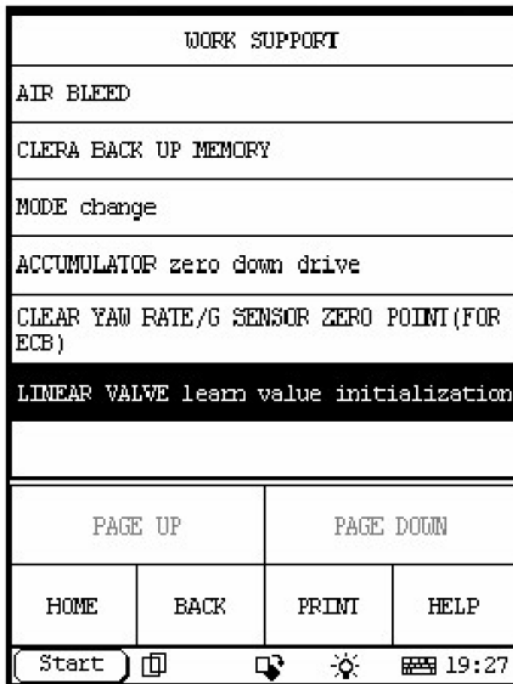

图3

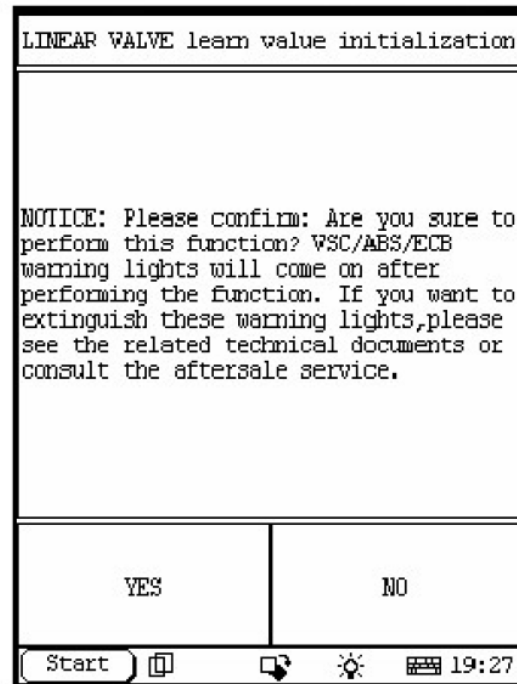
After brake executor is replaced, the brake pedal journey sensor and brake control ECU will execute the linear valve learn value initialization function. It will initialize the communication between brake executor, brake pedal journey sensor and brake control ECU.

Click [YES] in fig.2 if confirm the operation to enter Step 1/3. See fig.4.

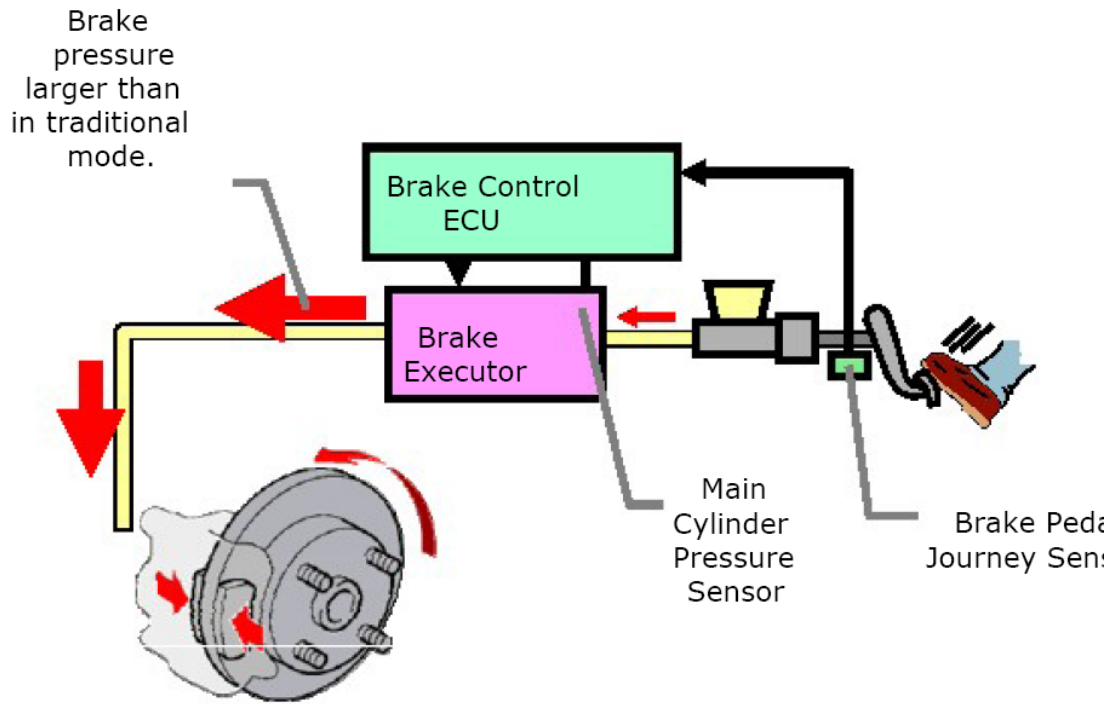

图4

Note: please operate with ignition switch ON and in P position. Then press [YES] to enter the Step 2/3 as shown in fig.5. Please operate following instructions.



图5

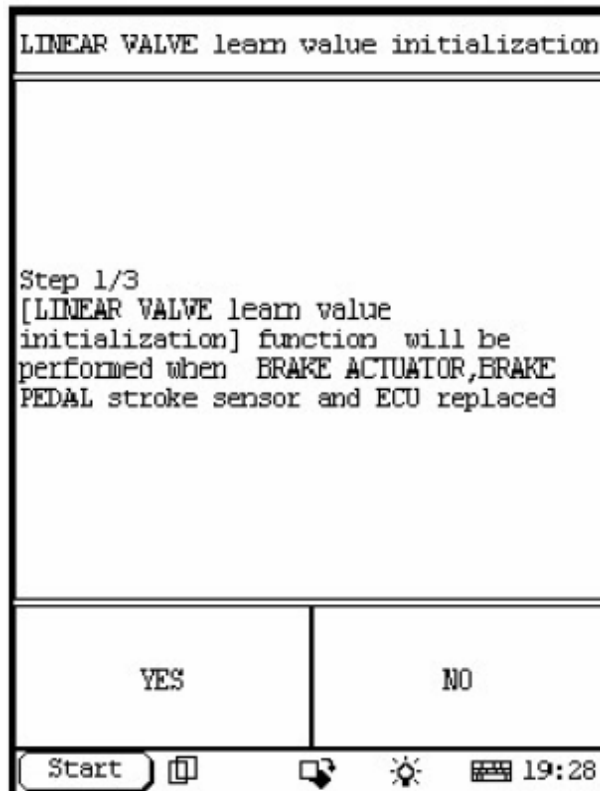

图6

Note: VSC/ABS warning light will be light after doing this operation. The light can't be cleared by clearing DTC function. The DTC is C1345/66-non-learning linear valve branch is abnormal. .

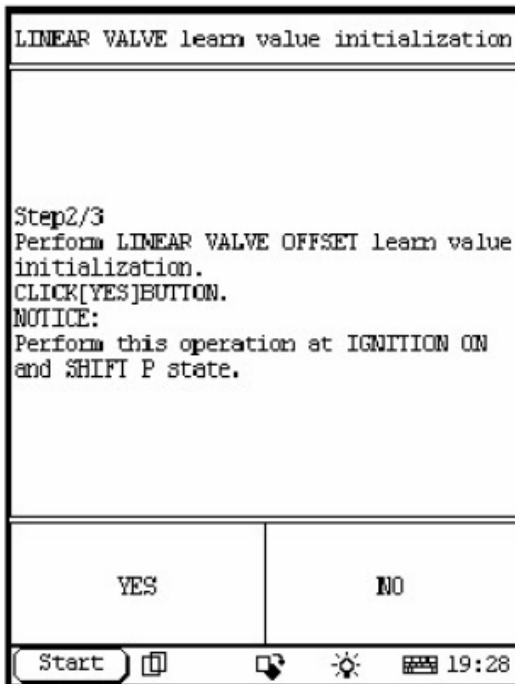
The operation for extinguishing warning light is available in MODE CHANGE menu:

1. Turn ignition key ON when warning light is lit.
2. Turn ignition switch ON and enter the WORKING SUPPORT menu of ABS.
3. Under MODE CHANGE menu, make it in check mode.

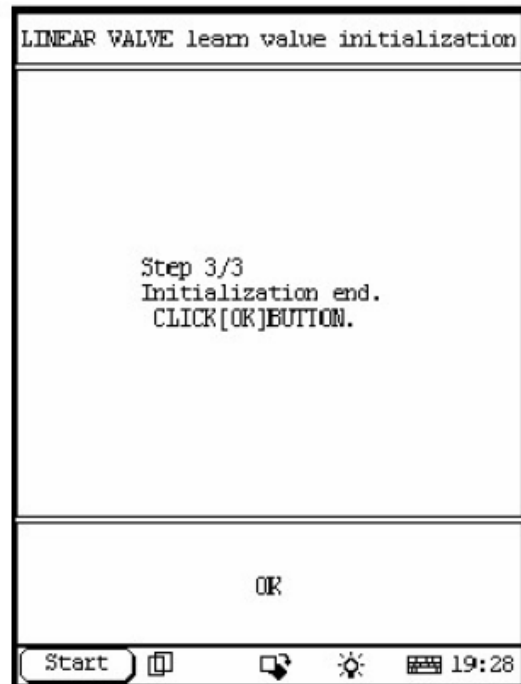

图7



图8

Select [NO] to enter check mode in fig. 8.

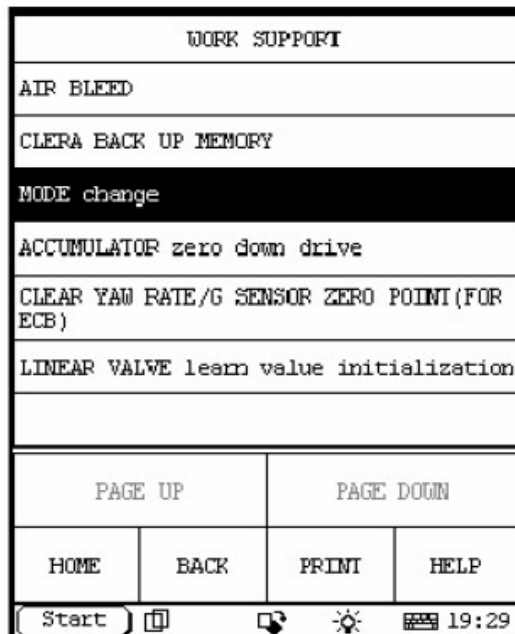

图9

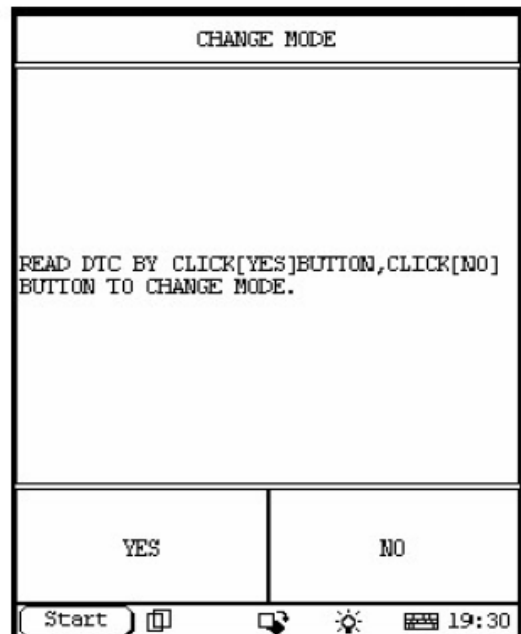

图10

4. Now, ECB warning light will be flash. If not, please repeat the operation as mentioned above till the frequency of warning light turn 1Hz to 4Hz.

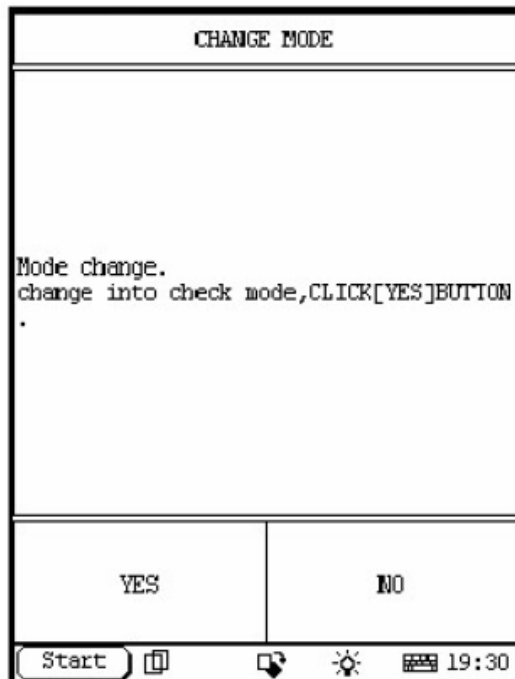
Note: the frequency of unit time to be set is 1Hz.

5. It will take about 1 minute for the operation, which will be different as different vehicle.
6. Now, enter normal mode(or turn ignition switch OFF to normal mode), the warning light will be extinguished.

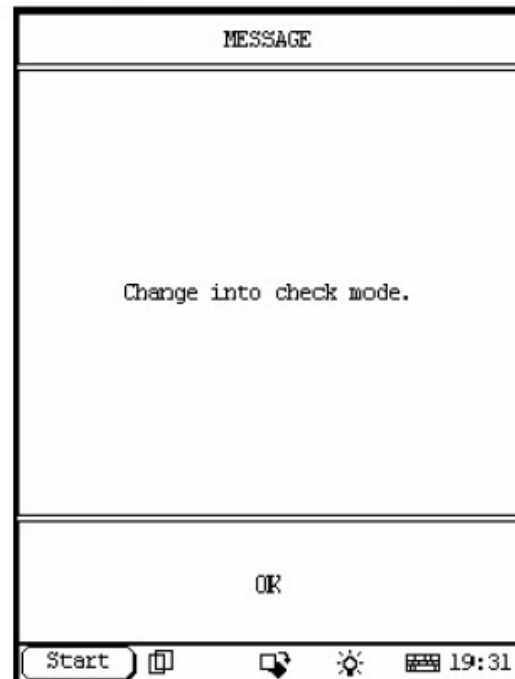
Click "OK" in fig.10 to normal mode.

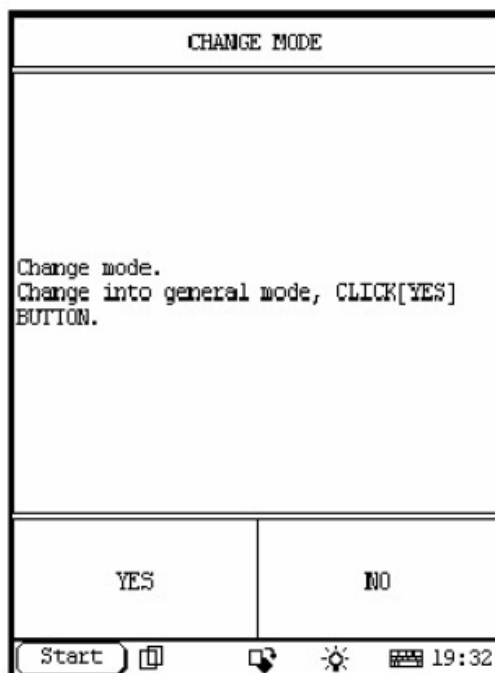

图 11

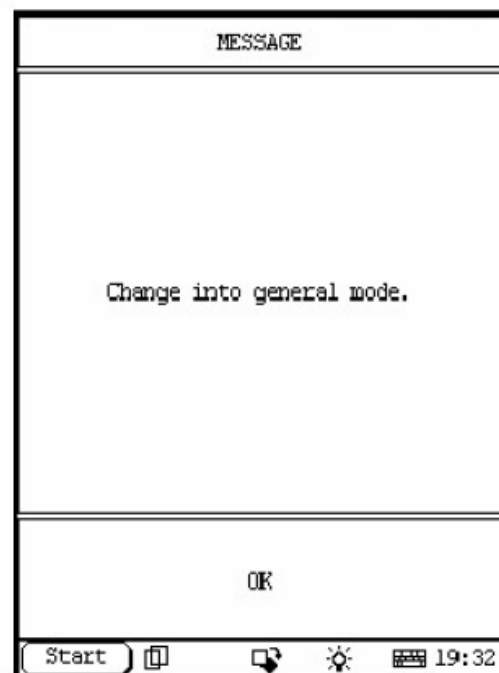

图 12