

U0126 SAS-ITM CAN COMM. LINE

COMPONENT LOCATION

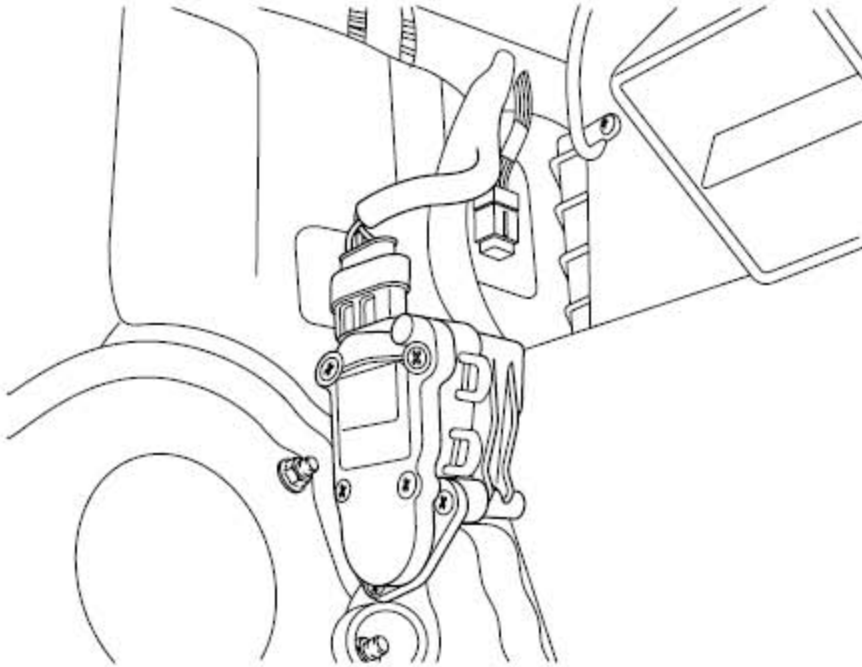

GENERAL DESCRIPTION

CAN communication is a parallel circuit to interchange information among each units. CAN communication can share much information with units more faster and more efficiently by using specified language.

CAN-High line is twisted with CAN-Low line as a purpose in preventing from a noise. ITM-ECU performs active control by sharing signals of engine RPM, APS, shift position, torque reduction.

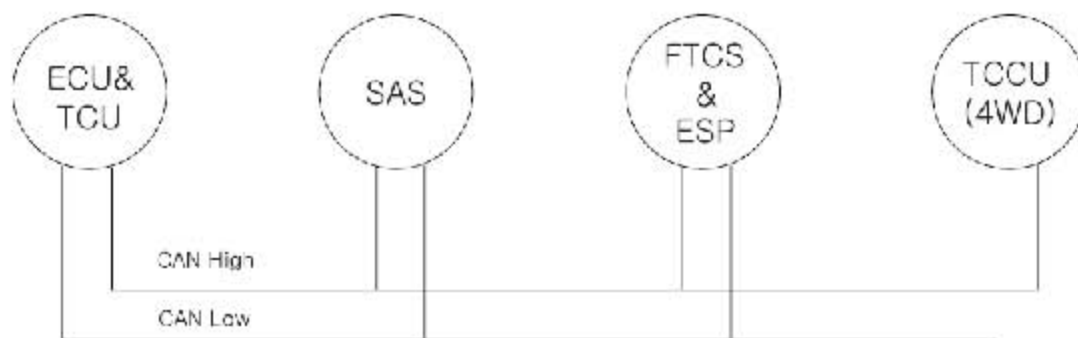

DTC DESCRIPTION

This code related to communication line between ECU and TCCU is set when CAN signal from ECU can't received formore than 1sec or ECU internal error occur. If failure is detected TCCU prohibits the ITM control and cuts the current to control coil.

DTC DETECTING CONDITION

Item	Detecting Condition	Possible Cause
DTC Strategy	SAS-ITM Communication Line, or ECU side malfunction	<ul style="list-style-type: none"> • CAN HIGH/LOW circuit open/short • Faulty SAS(ESP only) • Faulty TCCU
Enable Conditions	Message present 1.0 sec self clearing	
Threshold Value	Loss of the Wheel Speed sensor signals for greater than one (1) second, and a fault will be set	
Diagnostic Time	1 sec	
MIL on condition	0.5 Sec	
Fail Safe	See Speed Sensors	

SIGNAL WAVEFORM & DATA

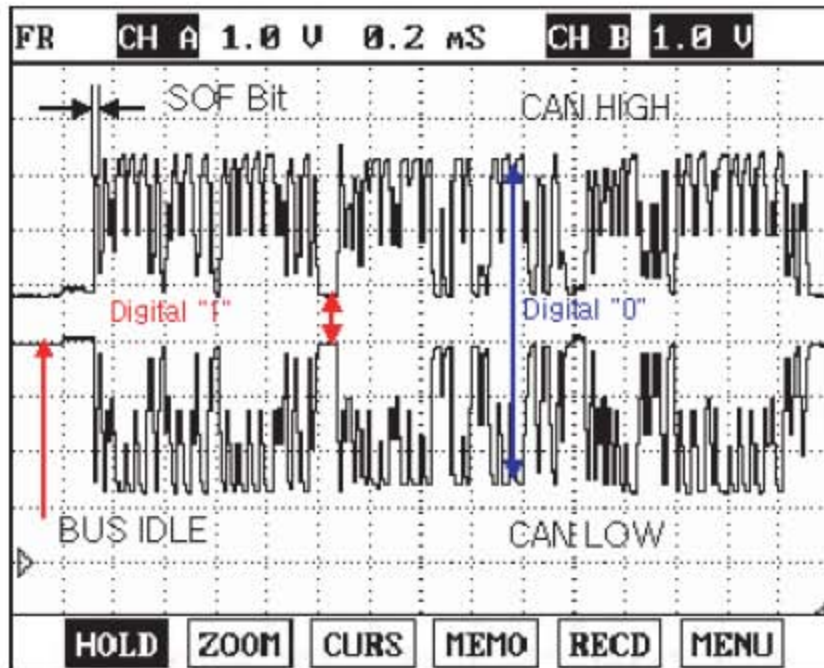

FIG.1)

FIG.1) CAN Signal : high & low

TERMINAL AND CONNECTOR INSPECTION

- 1). Many malfunctions in the electrical system are caused by poor harness and terminals. Faults can also be caused by interference from other electrical systems, and mechanical or chemical damage.
- 2). Thoroughly check connectors for looseness, poor connection, bending, corrosion, contamination, deterioration, or damage.
- 3). Has a problem been found?

YES

- ▶ Repair as necessary and go to "Verification of Vehicle Repair" procedure.

NO

- ▶ Go to "CAN Signal Inspection " procedure.

CAN COMM. LINE INSPECTION

- 1). Ignition ON, Engine : ON.
- 2). TCCU connector : Connect.
- 3). Monitor signal waveform between terminal 4, 5 of TCCU harness connector
- 4). Shift to N Range.

Specification : Signal Waveform & Data

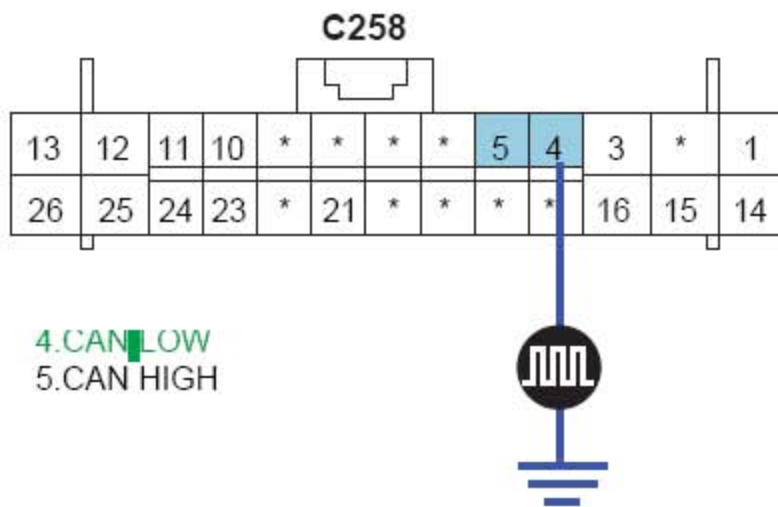

CAUTION

The above value is only for reference.
The actual value may differ from it according to various engine condition.

5). Is CAN Signal display near the specified value?

YES

- ▶ Fault is intermittent caused by poor contact in the sensor's and/or TCCU's connector or was repaired and TCCU memory was not cleared. Thoroughly check connectors for looseness, poor connection, bending, corrosion, contamination, deterioration, or damage. Repair or replace as necessary and then go to "Verification of Vehicle Repair" procedure.

NO

- ▶ Go to "CAN comm. Line Inspection" procedure.

CAN COMM. LINE INSPECTION

- 1). IG "OFF" & ENG "OFF"
- 2). TCCU connector : Disconnect.
- 3). Measure resistance between terminal "4" of the TCCU harness connector and terminal "5" of the TCCU harnessconnector.

Specification : Approx. 60Ω

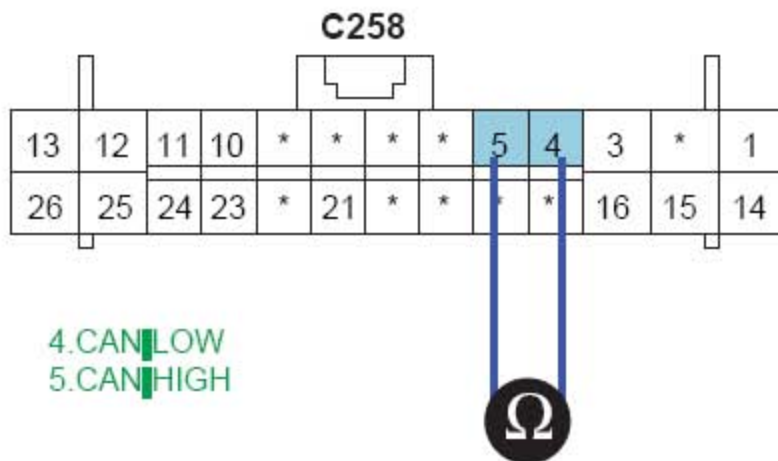

CAUTION

The above value is only for reference.

The actual value may differ from it according to various engine condition.

- 4). Is resistance display near the specified value?

YES

- ▶ Fault is intermittent caused by open or short in CAN signal harness or was repaired and TCCU memory was not cleared. Go to the applicable troubleshooting procedure.

NO

- ▶ Check for open/short in CAN communication line of TCCU circuit.
- ▶ Check for the signal or component of Engine control module.
- ▶ Repair as necessary and then go to "Verification of Vehicle Repair" procedure.

VERIFICATION OF VEHICLE REPAIR

- 1). Connect scan tool and select "Diagnostic Trouble Codes(DTCs)" mode.
- 2). Using scantool, Clear DTC.
- 3). Operate the vehicle within DTC Enable conditions in General information.
- 4). Are any DTCs present ?

YES

- ▶ Go to the applicable troubleshooting procedure.

NO

- ▶ System is performing to specification at this time.

LAUNCH