

B1475、B1479 CURTAIN AIRBAG

DTC DESCRIPTION

The CAB squib circuit consists of the SRSCM and two Curtain Airbags (CAB). It causes the SRS to deploy when the SRS deployment conditions are satisfied. The above DTC is recorded when short to ground is detected in the CAB squib circuit.

DTC	FAULT DESCRIPTION
B1475	CURTAIN AIRBAG [DRIVER] CIRCUIT SHORT TO GROUND
B1479	CURTAIN AIRBAG [PASSENGER] CIRCUIT SHORT TO GROUND

DTC DETECTING CONDITION

DTC	Condition	Probable cause
B1475 B1479	<ul style="list-style-type: none"> • Short to ground between CAB and SRSCM • Curtain Airbag (CAB) Malfunction • SRSCM Malfunction 	<ul style="list-style-type: none"> • Short to ground circuit on wiring harness • Curtain Airbag (CAB) squib • SRSCM

SCHEMATIC DIAGRAM

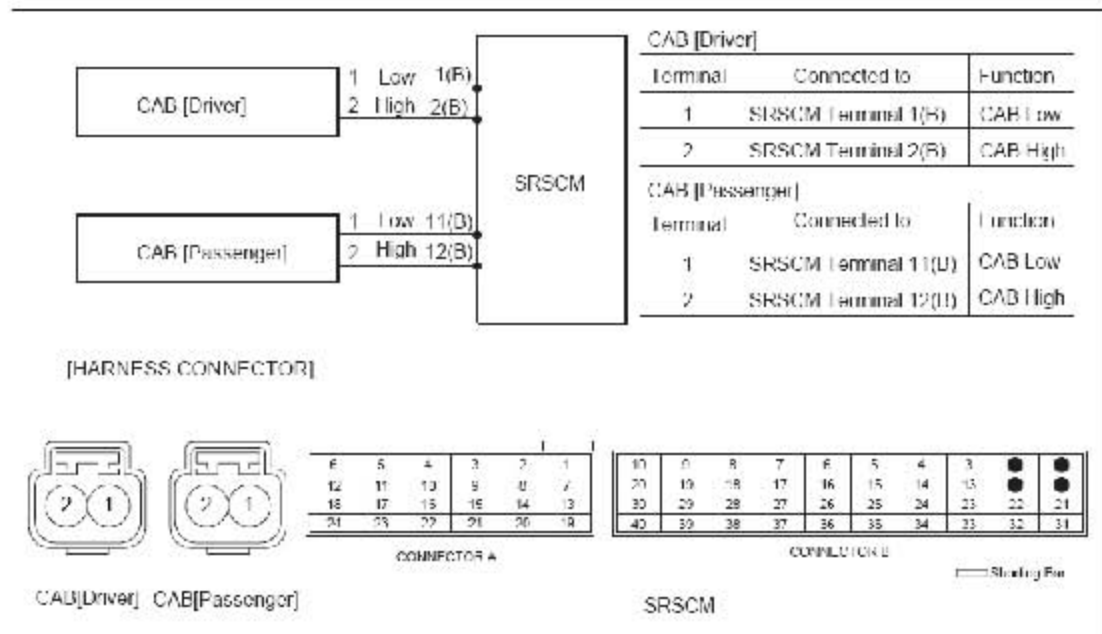

TERMINAL & CONNECTOR INSPECTION

Refer to the DESCRIPTION in this TROUBLESHOOTING section.

INSPECTION PROCEDURE

1). PREPARATION.

Refer to the DESCRIPTION in this TROUBLESHOOTING section.

2). CHECK SHORT TO BATTERY LINE

A) Measure resistance between the terminal 2 of CAB harness connector and chassis ground.

Specification (resistance) : infinite
--

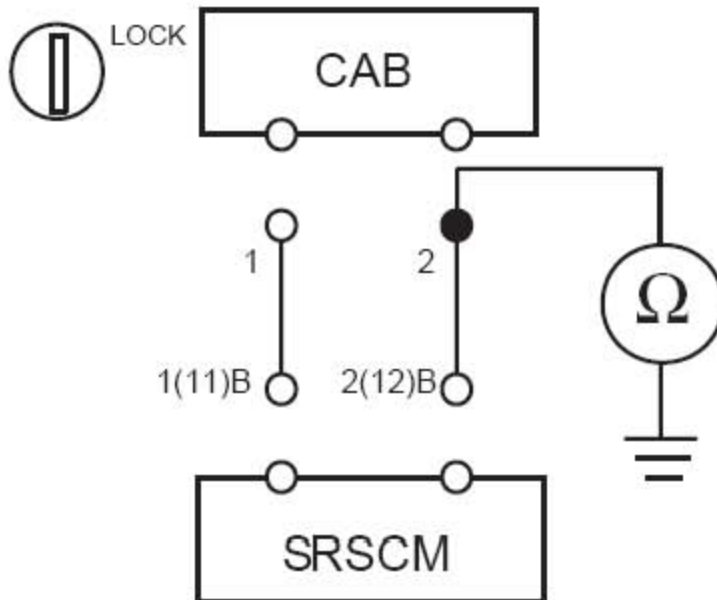

B) Is the measured voltage within specification?

YES

▶ Check the CAB Module..

NO

▶ Repair or replace the wiring harness between the CAB and the SRSCM.

3). CHECK THE CAB MODULE

A) Replace the Curtain Airbag(CAB) with a new one.

Refer to "Curtain Airbag(CAB)" section in this SERVICE MANUAL.

B) Install the DAB module and connect the DAB connector.

C) Connect the connectors of the PAB, SAB, CAB, BPT, FIS and SIS.

D) Connect the SRSCM connector.

E) Connect the battery negative cable to the battery.

F) Connect a Hi-Scan(Pro) to the data link connector.

G) Turn the ignition switch to ON and check the vehicle again.

Does Hi-Scan (Pro) indicate any DTC related to Curtain Airbag(CAB)?

YES

- ▶ Go to next step.

NO

- ▶ Replace CAB module.

4). CLEAR THE DTC AND CHECK THE VEHICLE AGAIN

Refer to the DESCRIPTION in this TROUBLESHOOTING section.