

brake system

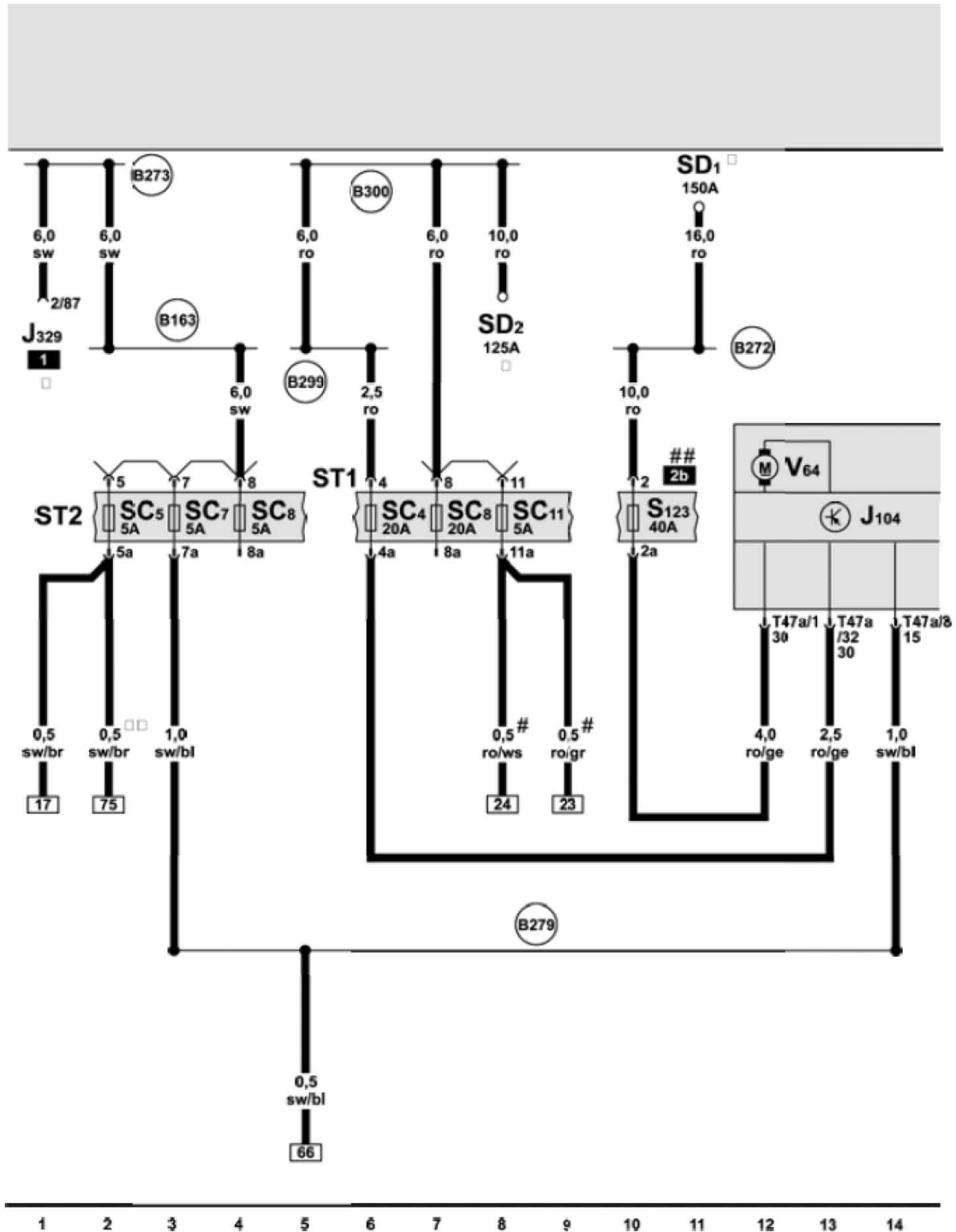

ws = white sw = black ro = red br = brown gn = green bl = blue
 gr = grey li = purple ge = yellow or = orange rs = pink

ABS control unit, ABS control unit fuse 1, ABS hydraulic pump

J104 - ABS control unit

J329 - Terminal 15 voltage supply relay

S123 - ABS control unit fuse 1

SC4 - Fuse 4 on fuse holder C

SC5 - Fuse 5 on fuse holder C

SC7 - Fuse 7 on fuse holder C

SC8 - Fuse 8 on fuse holder C

SC11 - Fuse 11 on fuse holder C

SD1 - Fuse 1 on fuse holder D

SD2 - Fuse 2 on fuse holder D

T47a - 47-pin connector, on ABS control unit

V64 - ABS hydraulic pump

B163 - Positive connection 1 (15), in interior wiring harness

B272 - Positive connection (30), in main wiring harness

B273 - Positive connection (15), in main wiring harness

B279 - Positive connection 3 (15a), in main wiring harness

B299 - Positive connection 3 (30), in main wiring harness

B300 - Positive connection 4 (30), in main wiring harness

- Relay and fuse carrier under driver seat
- models with manual gearbox
- cable installed as an option
- relay and fuse carrier centre dash panel

LAUNCH

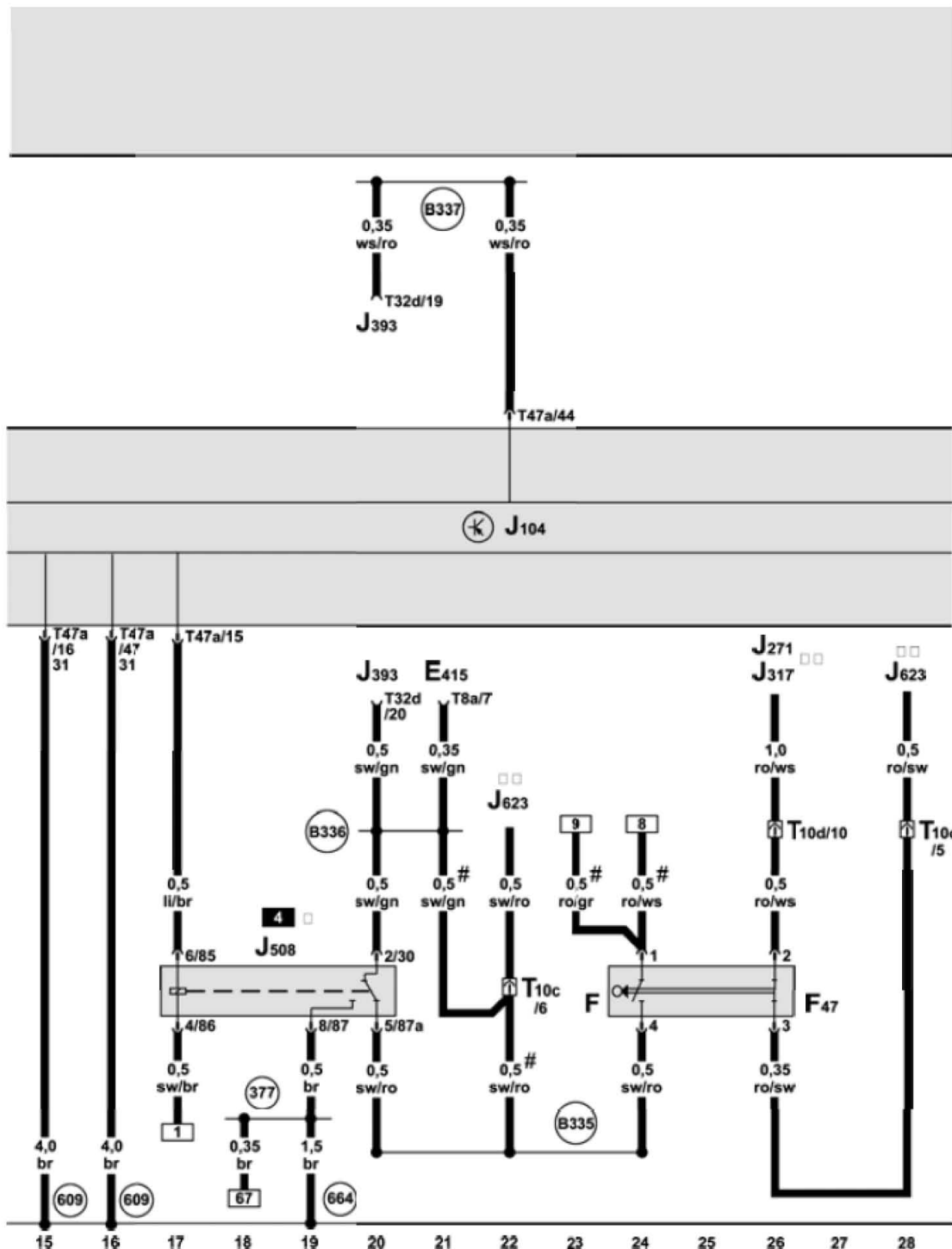

ws = white sw = black ro = red br = brown gn = green bl = blue
 gr = grey li = purple ge = yellow or = orange rs = pink

ABS control unit, brake light suppression relay, brake light switch, brake pedal switch

E415 - Entry and start authorisation switch

F - Brake light switch

F47 - Brake pedal switch

J104 - ABS control unit

J271 - Motronic current supply relay

- J317 - Terminal 30 voltage supply relay
- J393 - Convenience system central control unit
- J508 - Brake light suppression relay
- J623 - Engine control unit
- T8a - 8-pin connector, black, on entry and start authorisation switch
- T10c - 10-pin connector, pink, coupling station on electronics box, plenum chamber
- T10d - 10-pin connector, blue, coupling station on electronics box, plenum chamber
- T32d - 32-pin connector, on convenience system central control unit
- T47a - 47-pin connector, on ABS control unit
- 377 - Earth connection 12, in main wiring harness
- 609 - Earth point, on right in plenum chamber
- 664 - Earth point, on left behind dash panel
- B335 - Connection 1 (54), in main wiring harness
- B336 - Connection 2 (54), in main wiring harness
- B337 - Connection 3 (54), in main wiring harness
 - relay and fuse carrier centre dash panel
 - see engine Current Flow Diagram
 - cable installed as an option

LAUNCH

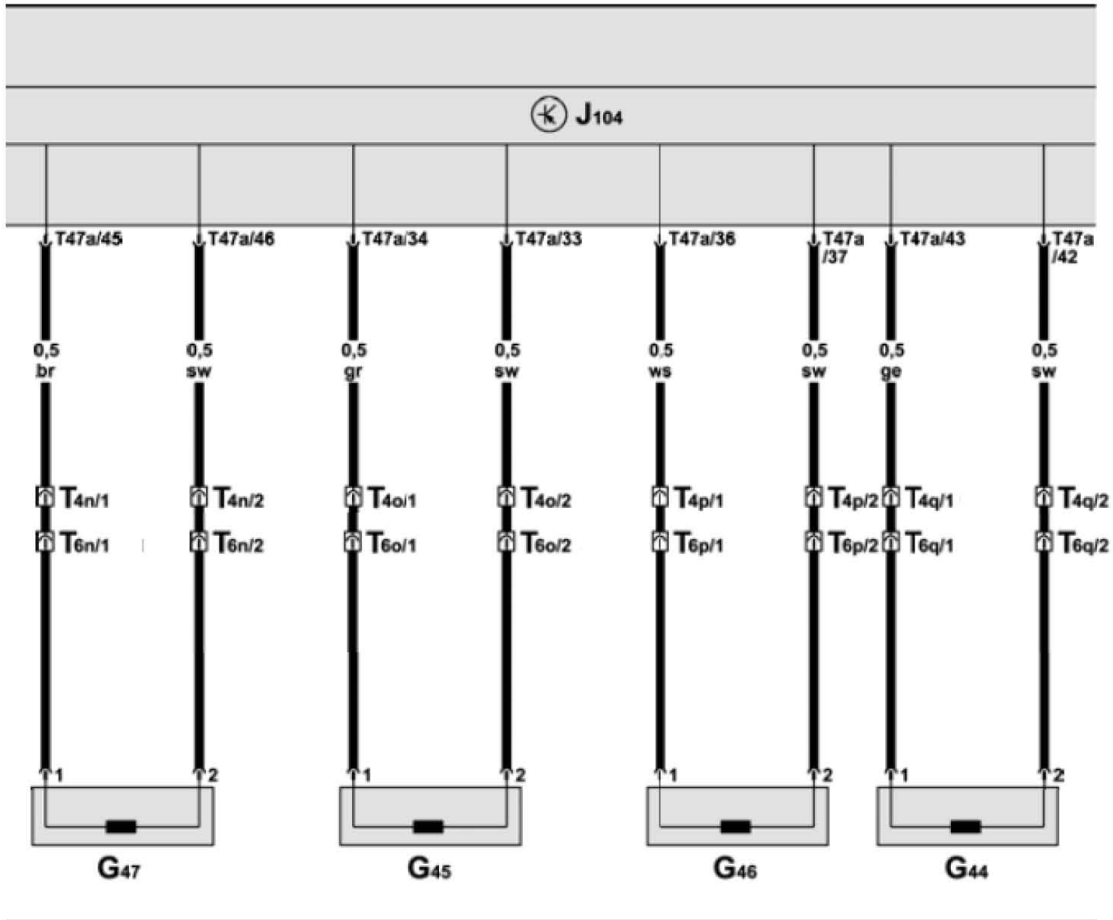

29	30	31	32	33	34	35	36	37	38	39	40	41	42
ws = white	sw = black	ro = red	br = brown	gn = green	bl = blue	gr = grey	li = purple	ge = yellow	or = orange	rs = pink			

ABS control unit, speed sensor

G44 - Rear right speed sensor

G45 - Front right speed sensor

G46 - Rear left speed sensor

G47 - Front left speed sensor

J104 - ABS control unit

T4n - 4-pin connector, black, in front left engine compartment

T4o - 4-pin connector, black, in front right engine compartment

T4p - 4-pin connector, black, on rear left vehicle floor

T4q - 4-pin connector, black, on rear right vehicle floor

T6n - 6-pin connector, black, in front left engine compartment

T6o - 6-pin connector, black, in front right engine compartment

- T6p - 6-pin connector, black, on rear left vehicle floor
- T6q - 6-pin connector, black, on rear right vehicle floor
- T47a - 47-pin connector, on ABS control unit
 - without adaptive suspension
 - with adaptive suspension

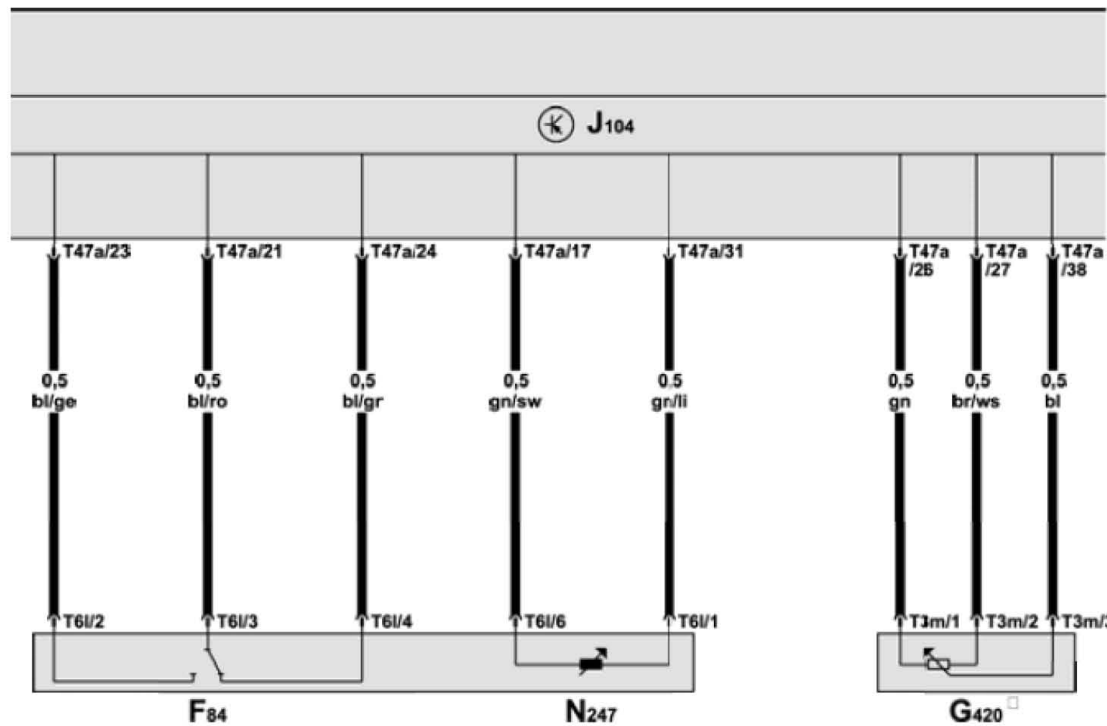

43	44	45	46	47	48	49	50	51	52	53	54	55	56
----	----	----	----	----	----	----	----	----	----	----	----	----	----

ws = white sw = black ro = red br = brown gn = green bl = blue
 gr = grey li = purple ge = yellow or = orange rs = pink

potentiometer for brake servo diaphragm movement, brake pressure solenoid valve

F84 - Brake pressure solenoid trip switch

G420 - potentiometer for brake servo diaphragm movement

J104 - ABS control unit

N247 - Brake pressure solenoid valve

T3m - 3-pin connector, black, on brake servo

T6l - 6-pin connector, black, on brake servo

T47a - 47-pin connector, on ABS control unit

- with adaptive cruise (ACC)

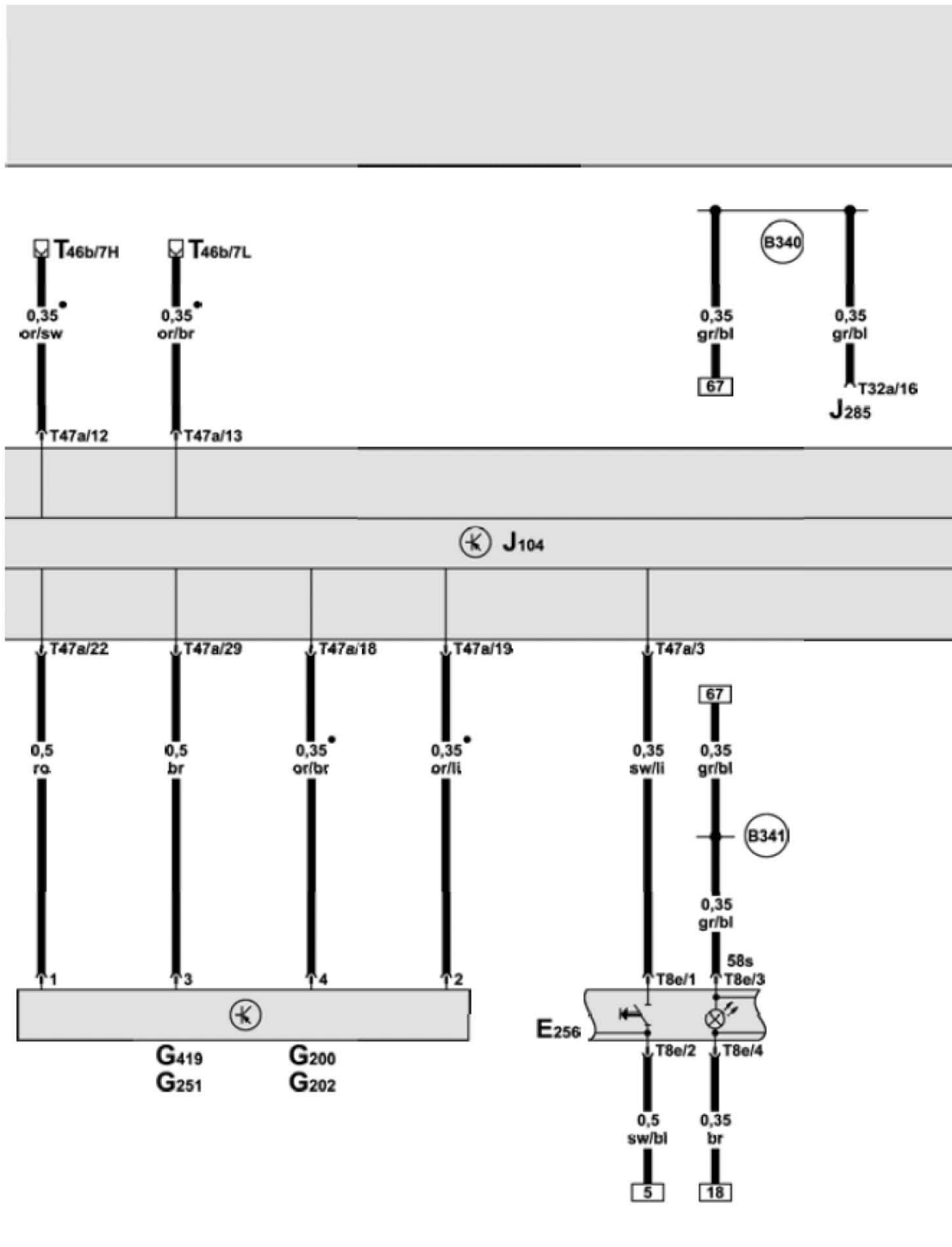

57	58	59	60	61	62	63	64	65	66	67	68	69	70
----	----	----	----	----	----	----	----	----	----	----	----	----	----

ws = white sw = black ro = red br = brown gn = green bl = blue
 gr = grey li = purple ge = yellow or = orange rs = pink

ABS control unit, ESP TCS and ESP button, lateral acceleration sender, yaw rate sender, longitudinal acceleration sender, ESP sensor unit

E256 - TCS and ESP button

G200 - Lateral acceleration sender

G202 - Yaw rate sender

G251 - Longitudinal acceleration sender

- G419 - ESP sensor unit
- J104 - ABS control unit
- J285 - Control unit in dash panel insert
- T8e - 8-pin connector, black, on centre vent switch module
- T32a - 32-pin connector, grey, on control unit in dash panel insert
- T46b - 46-pin connector, black, CAN separating connector right
- T47a - 47-pin connector, on ABS control unit
- B340 - Connection 1 (58s), in main wiring harness
- B341 - Connection 2 (58s), in main wiring harness
 - CAN bus (data wire)

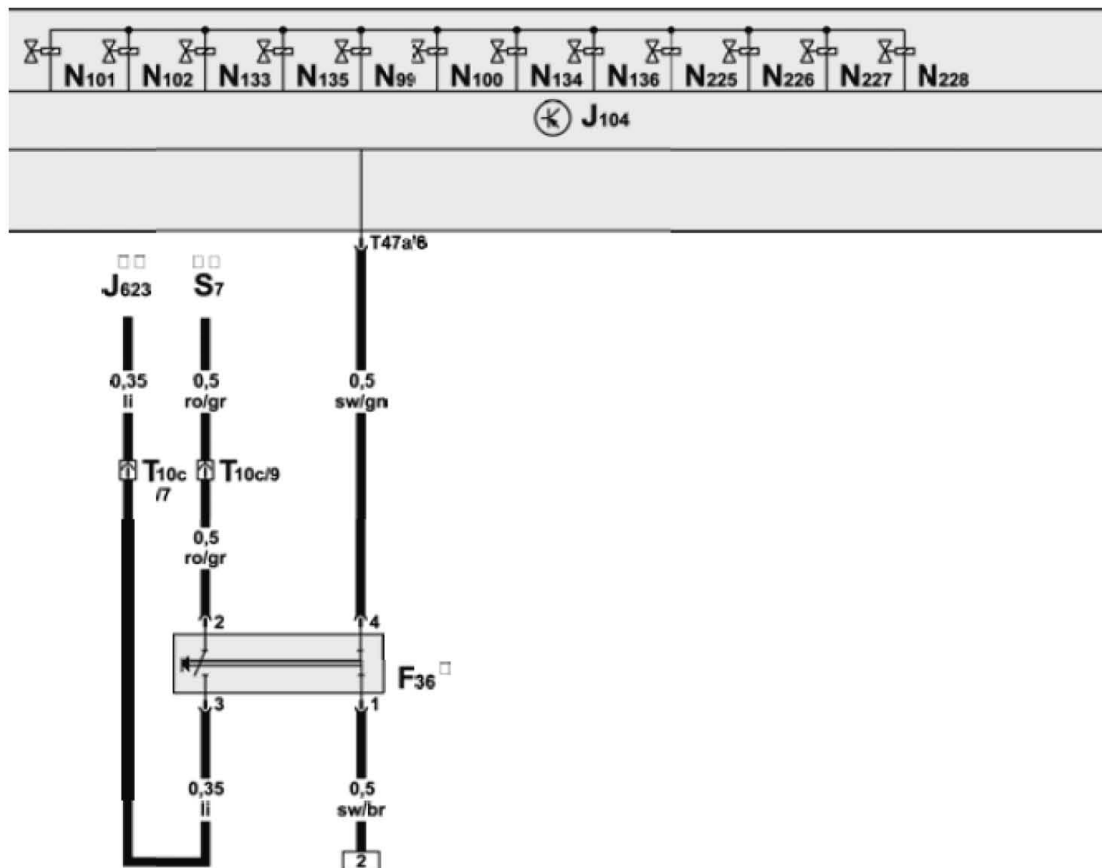
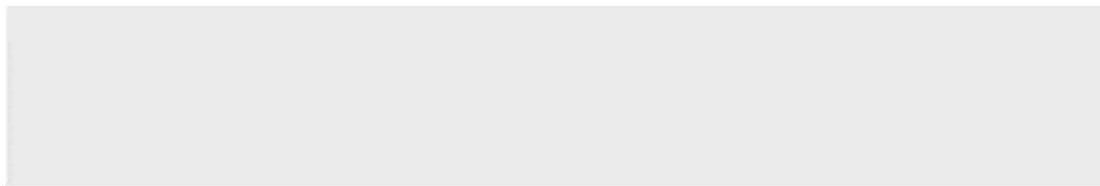

71 72 73 74 75 76 77 78 79 80 81 82 83 84

ws = white sw = black ro = red br = brown gn = green bl = blue
 gr = grey li = purple ge = yellow or = orange rs = pink

ABS control unit, clutch pedal switch, ABS inlet valve, ABS outlet valve, vehicle stabilization program switch valve, vehicle stabilization program high pressure valve

F36 - Clutch pedal switch
J104 - ABS control unit
J623 - Engine control unit
N99 - Front right ABS inlet valve
N100 - Front right ABS outlet valve
N101 - Front left ABS inlet valve
N102 - Front left ABS outlet valve
N133 - Rear right ABS inlet valve
N134 - Rear left ABS inlet valve
N135 - Rear right ABS outlet valve
N136 - Rear left ABS outlet valve
N225 - Vehicle stabilization program switch valve 1
N226 - Vehicle stabilization program switch valve 2
N227 - Vehicle stabilization program high pressure valve 1
N228 - Vehicle stabilization program high pressure valve 2
S7 - Fuses in relay plate fuse holder
T10c - 10-pin connector, pink, coupling station on electronics box, plenum chamber
T47a - 47-pin connector, on ABS control unit

- only manual gearbox
- see engine Current Flow Diagram

LAUNCH